



TM 10-5410-223-24P

TECHNICAL MANUAL

ORGANIZATIONAL, DIRECT AND GENERAL SUPPORT, MAINTENANCE
REPAIR PARTS AND SPECIAL TOOLS LIST

CONTAINER, SERVICE, WARD, RIGID CONSTRUCTION, APPROXIMATE
EXPANDED DIMENSION, 10 FT, 10³/₄ INCHES LONG,
12 FT WIDE 7 FT 3 INCHES HIGH
FSN 5410-809-6634

HEADQUARTERS, DEPARTMENT OF THE ARMY
NOVEMBER 1970

**ORGANIZATIONAL, DIRECT AND GENERAL SUPPORT, MAINTENANCE
 REPAIR PARTS AND SPECIAL TOOLS LISTS**

**CONTAINER, SERVICE, WARD, RIGID CONSTRUCTION, APPROXIMATE
 EXPANDED DIMENSION, 10 FT, 10¾ INCHES LONG, 12 FT WIDE,
 7 FT 3 INCHES HIGH FSN 5410-809-6634**

Current as of 10 October 1970

	Paragraph	Page
Section I. INTRODUCTION		
Scope	1	i
General	2	i
Explanation of columns	3	i
Special information	4	v
How to locate repair parts	5	v
Abbreviations	6	v
Federal supply codes for manufacturers	7	v
Recommendations for maintenance publication improvements	8	vi
II. PRESCRIBED LOAD ALLOWANCE		1
III. REPAIR PARTS FOR ORGANIZATIONAL MAINTENANCE		3
	Listing Page	Illus. Figure
Group 01. Airlock Adapter, Tie Down Assembly	3	
Airlock adapter		1
Tie down assembly		2
02. Shelter Body Assembly	3	
Container accessories		3
Folding roof		4
Folding floor		5
Removable door		6
Door assembly		7
End panel		10
End panel		11
Side panel		12
Section IV. SPECIAL TOOLS, TEST AND SUPPORT EQUIPMENT FOR ORGANIZATIONAL MAINTENANCE (NOT APPLICABLE)		
V. REPAIR PARTS FOR DS, AND GS MAINTENANCE	7	
01. Airlock Adapter, Tie Down Assembly	7	
Airlock adapter		1
Tie down assembly		2
02. Shelter Body Assembly	7	
Container accessories		3
Folding roof		4
Folding floor		5
Removable door		6
Door assembly		7
Roof panel		8

	Listing Page	Illus Figure
Roof panel (Inside)		9
End panel		10
End panel		11
Side panel		12
Floor panel		13
Section VI. SPECIAL TOOLS, TEST AND SUPPORT EQUIPMENT FOR DS, AND GS MAINTENANCE (NOT APPLICABLE)		
VII. FEDERAL STOCK NUMBER AND REFERENCE NUMBER INDEX	52	

SECTION I. INTRODUCTION

1. Scope

This manual lists repair parts, special tools, test and support equipment required for the performance of organizational, direct support, general support maintenance of the container.

2. General

This Repair Parts and Special Tools List is divided into the following sections:

a. Prescribed Load Allowance (PLA) — Section II. A composite listing of repair parts, special tools, test and support equipment having quantitative allowances for initial stockage at the organizational level.

b. Repair Parts — Section III. A list of repair parts authorized for the performance of maintenance at the organizational level in figure and item number sequence.

c. Special Tools, Test and Support Equipment — Section IV. A list of special tools, test and support equipment authorized for the performance of maintenance at the organizational level. (Not applicable).

d. Repair Parts — Section V. A list of repair parts authorized for the performance of maintenance at the direct support, general support level in figure and item number sequence.

e. Special Tools, Test and Support Equipment — Section VI. A list of special tools, test and support equipment authorized for the performance of maintenance at the direct support, general support, and depot level. (Not applicable).

f. Federal Stock Number and Reference Number Index — Section VII. A list of Federal stock numbers in ascending numerical sequence, followed by a list of reference numbers appearing in all of the listings, in alphanumeric sequence, cross-referenced to the illustration figure number and item number.

Note. Items not illustrated are cross-referenced to group number.

3. Explanation of Columns

The following provides an explanation of columns in the tabular lists in sections II through VI.

a. Source, Maintenance, and Recoverability Codes (SMR).

Note. Common hardware items known to be readily available in Army supply channels are assigned Maintenance codes only. Source codes, Recoverability codes, and Maintenance Allowances are not assigned to this category.

(1) Source code indicates the selection status and source for the listed item. Source codes used are:

Code	Explanation
P	Repair parts, special tools and test equipment supplied from the GSA/DSA, or Army supply system, and authorized for use at indicated maintenance categories.
P2	Repair parts, special tools and test equipment which are procured and stocked for insurance purposes because the combat or military essentiality of the end item dictated that a minimum quantity be available in the supply system.
M	Repair parts, special tools and test equipment which are not procured or stocked, as such, in the supply system but are to be manufactured at indicated maintenance levels.
A	Assemblies which are not procured or stocked as such, but are made up of two or more units. Such component units carry individual stock number and descriptions, are procured and stocked separately and can be assembled to form the required assembly at indicated maintenance categories.
X	Parts and assemblies that are not procured or stocked because the failure rate is normally below that of the applicable end item or component. The failure of such part or assembly should result in retirement of the end item from the supply system.
X1	Repair parts which are not procured or stocked. The requirement for such items will be filled by the next higher assembly or component.
X2	Repair parts, special tools and test equipment which are not stocked and have no foreseen mortality. The indicated maintenance category requiring such repair parts will attempt to obtain the parts through cannibalization or salvage, the item may be requisitioned with exception data, from the end item manager, for immediate use.
G	Major assemblies that are procured with PEMA funds for initial issue only as exchange assemblies at DSU and GSU level. These assemblies will not be stocked above the DS and GS level or returned to depot supply level.

(2) Maintenance code indicates the lowest category of maintenance authorized to install the listed item. The maintenance codes are:

Code	Explanation
O	Organizational maintenance
F	Direct support maintenance
H	General support maintenance

(3) Recoverability code indicates whether un-serviceable items should be returned for recovery or salvage. Items not coded are expandable. Recoverability codes are:

Code	Explanation
R	Applied to repair parts, (assemblies and components) special tools and test equipment which are con-

Code

Explanation

	considered economically repairable at direct and general support maintenance levels. When the item is no longer economically repairable, it is normally disposed of at the GS level. When supply considerations dictate, some of these repair parts may be listed for automatic return to supply for depot level repair as set forth in AR 710-50. When so listed, they will be replaced by supply on an exchange basis.
S	Repair parts, special tools, test equipment and assemblies which are economically repairable at DSU and GSU activities and which normally are furnished by supply on an exchange basis. When items are determined by a GSU to be uneconomically repairable, they will be evacuated to a depot for evaluation and analysis before final disposition.
T	High dollar value recoverable repair parts, special tools and test equipment which are subject to special handling and are issued on an exchange basis. Such items will be repaired or overhauled at depot maintenance activities only. No repair may be accomplished at lower levels.
U	Repair parts, special tools and test equipment specifically selected for salvage by reclamation units because of precious metal content, critical materials, high dollar value or reusable casings or castings,

b. Federal Stock Number. Indicates the Federal stock number assigned to the item and will be used for requisitioning purposes.

c. Description. Indicates the Federal item name and any additional description of the item required. Assembly components and subassemblies are indented under major assemblies. The abbreviation "w/e" when used as a part of the nomenclature, indicates the Federal stock number includes all armament, equipment, accessories, and repair parts issued with the item. A part number or other reference number is followed by the applicable 5-digit Federal supply code for manufacturers in parenthesis. Repair parts quantities included in kits and sets are shown in front of the repair part name. Material required for manufacture or fabrication is identified.

d. Unit of measure (U/M). A two-character alphabetic abbreviation indicating the amount or quantity of the item upon which the allowances are based, e.g., ft, ea, pr, etc.

e. Quantity Incorporated in Unit. Indicates the quantity of the item used in the assembly group. A "V" appearing in this column in lieu of a quantity indicates that a definite quantity cannot be indicated (e.g., shims, spacers, etc.).

f. Fifteen-Day Organizational Maintenance Allowance.

(1). The allowance columns are divided into four subcolumns. Indicated in each subcolumn opposite the first appearance of each item is the total quantity of the items authorized for the number of equipments supported. Subsequent appearances of the

same item will have the letters "REF" in the allowance column. To locate the referenced item, locate the FSN or reference number in the index. The earliest figure and item number is the referenced item. Items authorized for use as required but not for initial stockage are identified with an asterisk in the allowance column.

(2) The quantitative allowance for organizational level of maintenance represents one initial prescribed load for a 15-day period for the number of equipments supported. Units authorized additional prescribed loads, multiply the number of prescribed loads by the quantity in the appropriate density column to determine the number of repair parts authorized.

(3) To determine allowances when supporting more than 100 of these equipments: First, divide the number of equipments supported by 100 by moving the decimal two spaces left; second, multiply the result by the quantity in the 51-100 density column. Example, authorized allowance for 51-100 equipments is 12; for 140 equipments, multiply 12 by 1.40 or 16.80 rounded off to 17 parts required.

(4) Subsequent changes to allowances will be limited as follows: No change in the range of items is authorized. If additional items are considered necessary, recommendation should be forwarded to the U.S. Army Mobility Equipment Command for exception or revision to the allowance list. Revisions to the range of items authorized will be made by the U.S. Army Mobility Equipment Command based upon engineering experience, demand data, or TAERS information.

g. Thirty-Day DS/GS Maintenance Allowances.

Note. Allowances in GS Column are for GS maintenance only.

(1) The allowance columns are divided into three subcolumns. Indicated in each subcolumn, opposite the first appearance of each item, is the total quantity of items authorized for the number of equipments supported. Subsequent appearances of the same item will have the letters "REF" in the applicable allowance column. To locate the referenced item locate the FSN or reference number in the index. The earliest figure and item number is the referenced item. Items authorized for use as required but not for initial stockage are identified with an asterisk in the allowance column.

(2) The quantitative allowances for DS-GS levels of maintenance will represent initial stockage for a 30-day period for the number of equipments supported.

(3) To determine allowances when supporting more than 100 of these equipments: First, divide the number of equipments supported by 100 by moving the decimal two places left; second, multiply

the result by the quantity in the 51-100 density column. Example, authorized allowance for 51-100 equipments is 40; for 150 equipments multiply 40 by 1.50 or 60 parts required.

h. One-Year Allowance Per 100 Equipments/Contingency Planning Purposes. Indicates opposite the first appearance of each item the total quantity required for distribution and contingency planning purposes. The range of items indicates total quantities of all authorized items required to provide for adequate support of 100 equipments for one year. Subsequent appearances of the same item will have the letters "REF" in the allowance column.

i. Depot Maintenance Allowance Per 100 Equipments. Indicates opposite the first appearance of each item the total quantity authorized for depot maintenance of 100 equipments. Subsequent appearances of the same item will have the letters "REF" in the allowance column. Items authorized for use as required but not for initial stockage are identified with an asterisk in the allowance column.

j. Illustration. This column is divided as follows:

(1) *Figure number.* Indicates the figure number of the illustration in which the item is shown.

(2) *Item number.* Indicates the callout number used to reference the item in the illustration.

4. Special Information

a. Repair parts mortality has been based on 8750 hours operation per year.

b. Parts which require manufacture or assembly at a category higher than that authorized for installation will indicate in the source column the higher category.

c. The following publications pertain to container, service ward and its components:

TM 10-5410-223-10	Operator's Manual
TM 10-5410-223-24	Organizational, Direct and General Support Maintenance Manual

d. The same illustrations are used to illustrate the repair parts and special tools listed in both organizational maintenance section and direct and general support maintenance section.

5. How to Locate Repair Parts

a. When Federal stock number or reference number is unknown:

(1) *First.* Using the table of contents determine the assembly group within which the repair part belongs. This is necessary since illustrations are prepared for assembly groups, and listings are divided into the same groups.

(2) *Second.* Find the illustration covering the as-

sembly group to which the repair part belongs.

(3) *Third.* Identify the repair part on the illustration and note the illustration figure and item number of the repair part.

(4) Using the Repair Parts Listings, find the assembly group to which the repair part belongs and locate the illustration figure and item number noted on the illustration.

b. When Federal stock number or reference is known:

(1) *First.* Using the Index of Federal Stock Numbers and Reference Numbers find the pertinent Federal stock number or reference number. This index is in ascending FSN sequence followed by a list of reference numbers in alpha-numeric sequence, cross-referenced to the illustration figure and item number.

(2) *Second.* Using the Repair Parts Listing, find the assembly group of the repair part and the illustration figure number and item number referenced in the Index of Federal Stock Numbers and Reference Numbers.

c. When the Federal stock number or reference number is known and the repair part is not illustrated:

(1) *First.* Using the Index of Federal Stock Numbers and Reference Numbers find the pertinent Federal stock number or reference number in the section titled "Items Not Illustrated" and not the group number. This section is in ascending FSN sequence followed by a list of reference numbers in alpha-numeric sequence, cross-referenced to assembly group number.

(2) *Second.* Using the Table of Contents, locate the assembly group number and page number.

(3) *Third.* Using the applicable group number and page number, locate the pertinent stock number or reference number in the Repair Parts Listing. Items which are not illustrated are listed at the end of the assembly group to which they belong.

6. Abbreviations

thd	thread
in.	inch (es)
lg	long (length)
dia	diameter
mtg	mounting
ft	foot (feet)
ea	each
assy	assembly

7. Federal Supply Codes for Manufacturers

Code	Manufacturer
02106	Missouri Research Laboratories Inc.
03481	Goodrich B F Co. Aerospace and Defense Products Division

<i>Code</i>	<i>Manufacturer</i>
07707	United Shoe Machinery Corp Fastener Division
10424	Magesco Inc.
19220	Eberhard Mfg. Co.
19704	Aer-Bea Co. Inc.
25472	Goodrich B F Co.
26533	Zero Mfg. Co. Shelter Division
32868	Unell Mfg. Co.
45722	Parker Kalon Div of General American Transportation Corp
56878	Standard Pressed Steel Co.
61864	United-Carr Inc.
70167	Air Cruisers Co.
73197	Hi-Shear Corp
79136	Waldes Kohinoor Inc.
79144	Vellumoid Division Federal-Mogul Corp
80205	United States of America Standards Institute
81337	Army Natick Laboratories Mechanical Engineering Div
81348	Federal Specifications Promulgated by General Services Administration
81349	Military Specifications Promulgated by Standardization Div Directorate of Logistic Service DSA
82240	Simmons Fastener Corp

<i>Code</i>	<i>Manufacturer</i>
84256	Avdel Inc.
88044	Aeronautical Standards Group Dept of Navy and Air Force
94222	South Chester Corp
96603	Eastern Rotorcraft Corp
96906	Military Standards Promulgated by Standardization Div Directorate of Logistic Service DSA
98003	Nielsen Hardware Corp
99862	Carr Lane Mfg. Co.

8. Recommendations for Maintenance Publication Improvements

Report of errors, omissions, and recommendations for improving this publication by the user is encouraged. Reports should be submitted on DA Form 2028 (Recommended Changes to Publications) and forwarded direct to Commanding General, U.S. Army Mobility Equipment Command, ATTN: AMSME-MPP 4300 Goodfellow Boulevard, St. Louis, Mo. 63120.

(1) FEDERAL STOCK NUMBER	(2) DESCRIPTION	(3) 15-DAY ORGANIZATIONAL MAINTENANCE ALLOWANCE			
		(a) 1-5	(b) 6-20	(c) 21-50	(d) 51-100
	SECTION 11 - PRESCRIBED LOAD ALLOWANCE				
	GROUP 01 - AIRLOCK ADAPTER TIE DOWN ASSEMBLY				
8340-205-2759	SLIP TENT LINE (81349) MIL-S1734TY11				1
	BOLT, EYE (96906) MS51937-3			1	1
	GROUP 02 - SHELTER BODY ASSEMBLY				
5305-043-2682	SCREW: STRIKER MTG (96906) MS24694S98			1	1
5305-253-2606	SCREW, THUMB: PLATE MTG (02106) 889508-1			1	1
5305-267-8977	SCREW: LOCK ASSEMBLY MTG (96906) MS90726-10			1	1
5305-269-3235	SCREW: JACK ASSEMBLY MTG (96906) MS90727-99		1	1	2
5306-144-4004	BOLT: SUPPORT MTG (88044) AN6-12A				1
5306-150-9105	BOLT: HANDLE MTG (88044) AN4-4A			1	1
5306-838-7487	SCREW: CLIP MTG (80205) NAS1105-4			1	1
5310-167-0812	WASHER: BRACKET MTG (88044) AN960C10L			1	1
5310-167-0808	WASHER: LEVEL ASSEMBLY MTG (88044) AN960-10			1	1
5310-167-0821	WASHER: JACK ASSEMBLY MTG (88044) AN960-616		1	1	2
5310-167-0823	WASHER: SUPPORT MTG (88044) AN960-816			1	1
5310-167-0839	WASHER, LOCK: SUPPORT MTG (88044) AN960-816L			1	1
5310-176-8121	NUT: CLAMP MTG (88044) AN354C416			1	1
5310-188-3744	WASHER: LOCK ASSEMBLY MTG (96906) MS9320-09			1	1
5310-529-6513	WASHER: PLATE MTG (79144) S8157C127-156			1	1
5310-595-5427	WASHER, FLAT: HANDLE MTG (88044) AN960-416			1	1
5315-839-2325	PIN, CUTTER (96906) MS24665-132			1	1
5340-780-7183	DOOR STOP			2	2
5360-251-4006	SPRING: CABLE STOWAGE (26533) ZS014-194				1
5410-022-2669	JACK ASSEMBLY, MAIN LIFTING (02106) 889220-1				1
5410-221-8902	PLATE, CLAMP (02106) 889507-1			1	1
5410-522-2479	POST, CORNER (02106) 890363				1

(1) FEDERAL STOCK NUMBER	(2) DESCRIPTION	(3) 15-DAY ORGANIZATIONAL MAINTENANCE ALLOWANCE			
		(e) 1-5	(b) 6-20	(c) 21-50	(d) 51-100
	SECTION 11 - PRESCRIBED LOAD ALLOWANCE				
	BOLT, SHOULDER (99862) CL32SS			2	2
	BOLT, SHOULDER (99862) CL4SS			1	1
	CLIP, SPRING RETAINER (26533) ZSD06-195				2
	LOCK ASSEMBLY, MODIFIED (26533) ZSD18-180-401				1
	SCREW, SHOULDER (56878) 12705L8C8C			2	2
	CLAMP, AIRLOCK ADAPTER (02106) 891780-1			1	1
	CLAMP, AIRLOCK ADAPTER (02106) 891781-1			1	1

(1) SMR CODE	(2) FEDERAL STOCK NUMBER	(3) DESCRIPTION REF NUMBER & MFR CODE	(4) UNIT OF MEAS USABLE ON CODE	(5) QTY INC IN UNIT	(6) 15-DAY ORGANIZATIONAL MAINTENANCE ALW				(7) ILLUS- TRATION	
					(a)	(b)	(c)	(d)	(a)	(b)
					1-5	6-20	21-50	51-100	FIG. NO.	ITEM NO.
		SECTION III - REPAIR PARTS FOR ORGANIZATIONAL MAINTENANCE								
		GROUP 01 - AIR LOCK ADAPTER, TIE DOWN ASSEMBLY								
P O		ADAPTER, AIR LOCK 5-4-1630-1 (81337)	EA	1	*	*	*	*	1	1
P O		SUPPORT, BOW ASSEMBLY 5-4-1630-3 (81337)	EA	1	*	*	*	*	1	2
M O		LINE, GUY 5-4-1630-11 (81337) MANUFACTURE FROM:	EA	2					1	3
		ROPE, 5/16 IN. DIA BY 13 FT REQUIRED FOR EA LINE, FSN 4020-202-1345								
P O	8340-205-2759	SLIP TENT LINE MILS1734TY11 (81349)	EA	4	*	*	*	1	1	4
P O		BOLT, EYE: 3/8-16 THD SIZE, 2 7/8 IN. LG MS51937-3 (96906)	EA	4	*	*	1	1	1	5
M O		LINE, GUY 5-4-1630-10 (81337) MANUFACTURE FROM:	EA	2					1	6
		ROPE, 5/16 IN. DIA BY 8 FT REQUIRED FOR EA LINE, FSN 4020-202-1345								
X1		COVER ASSEMBLY 5-4-1630-4 (81337)	EA	1					1	12
P O	5340-042-8664	STRAP ASSEMBLY 697899-1 (02106)	EA	4	*	*	*	*	2	1
P O	5410-018-7538	NET WEB ASSEMBLY 697899-2 (02106)	EA	1	*	*	*	*	2	2
P O		STRAP ASSEMBLY, CARGO NET 889735-1 (02106)	EA	4	*	*	*	*		
		GROUP 02 - SHELTER BODY ASSEMBLY								
O		SCREW: CLAMP MTG MS35234-84 (96906)	EA	8					3	1
P O	5310-176-8121	NUT: CLAMP MTG AN354C416 (88044)	EA	8	*	*	1	1	3	2
O		CLAMP, AIR LOCK ADAPTER 891781-1 (02106)	EA	8					3	3
P O	5310-529-6513	WASHER: CLAMP MTG S8157C127-156 (79144)	EA	8	*	*	1	1	3	4
P O		SCREW, SHOULDER: SUPPORT MTG 12705L8C8C (56878)	EA	2	*	*	2	2	3	5
P O	5310-167-0823	WASHER: SUPPORT MTG AN960-816 (88044)	EA	2	*	*	1	1	3	6
P O	5306-838-7487	SCREW: CLIP MTG NAS1105-4 (80205)	EA	2	*	*	1	1	3	7
P O	5360-251-4006	SPRING, CABLE STOWAGE ZSD14-194 (26533)	EA	2	*	*	*	1	3	8
P O		CLIP, SPRING RETAINER ZSD06-195 (26533)	EA	2	*	*	*	1	3	9
P O		SCREW, SHOULDER: CABLE ASSEMBLY MOUNTING 12705L8C8C (56878)	EA	2	REF	REF	REF	REF	3	10

(1) SMR CODE	(2) FEDERAL STOCK NUMBER	(3) DESCRIPTION REF NUMBER & MFR CODE	(4) USABLE ON CODE	(5) UNIT OF MEAS QTY INC IN UNIT	(6) 15-DAY ORGANIZATIONAL MAINTENANCE ALW				(7) ILLUS- TRATION		
					(a)	(b)	(c)	(d)	(a)	(b)	
					1-5	6-20	21-50	51-100	FIG. NO.	ITEM NO.	
P O	5310-167-0823	WASHER; CABLE ASSEMBLY MTG AN960-816 (88044)		EA	2	REF	REF	REF	REF	3	11
P O	5410-522-2475	CABLE ASSEMBLY, FLOOR SUPPORT 890360-1 (02106)		EA	2	*	*	*	*	3	12
O		NUT: SUPPORT MTG MS20365-624 (96906)		EA	2					3	13
P O	5306-144-4004	BOLT: SUPPORT MTG AN6-12A (88044)		EA	2	*	*	*	1	3	14
P O	5340-067-9884	BODY, TURNBUCKLE MS21251-8L (96906)		EA	2	*	*	*	*	3	15
P O	5410-522-2481	SUPPORT ASSEMBLY FOLDING ROOF 890359-2 (02106) (COMPONENTS SAME AS SUPPORT ASSEMBLY, P/N 890359-1 (02106))		EA	1	*	*	*	*		
P O	5410-522-2480	SUPPORT ASSEMBLY FOLDING ROOF 890359-1 (02106)		EA	1	*	*	*	*		
P O		BOLT, SHOULDER: SUPPORT MTG, 1/2 IN. DIA X 1/2 IN. LG CL4SS (99862)		EA	1	*	*	1	1	3	19
P O	5310-167-0839	WASHER, LOCK: SUPPORT MTG AN960-816L (88044)		EA	2	*	*	1	1	3	20
P O		BOLT, SHOULDER: SUPPORT MTG, 1/2 IN. DIA X 3/4 IN. LG CL32SS (99862)		EA	1	*	*	1	1	3	21
P O	5410-522-2479	POST, CORNER 890363-1 (02106)		EA	2	*	*	*	1	3	34
O		SCREW: BRACKET MTG AN520C10R10 (88044)		EA	16					3	38
P O	5310-167-0812	WASHER: BRACKET MTG AN960C10L (88044)		EA	16	*	*	1	1	3	39
X20		BRACKET, STRAP CARGO NET 889751-1 (02106)		EA	8					3	40
P O		FABRIC ENCLOSURE ASSEMBLY 890340-1 (02106)		EA	1	*	*	*	*	3	41
P O	5410-221-8901	PLUG ASSEMBLY 890340-7 (02106)		EA	2	*	*	*	*	3	46
P O	5306-150-9105	BOLT: HANDLE MTG AN4-4A (88044)		EA	8	*	*	1	1	4	31
P O	5310-595-5427	WASHER, FLAT: HANDLE MTG AN960-416 (88044)		EA	8	*	*	1	1	4	32
X20		HANDLE ASSEMBLY ZSP3-003-2 (26533)		EA	2					4	33
O		SCREW: LEVEL ASSEMBLY MTG MS24584-57 (96906)		EA	2					5	21
P O	5310-167-0818	WASHER: LEVEL ASSEMBLY MTG AN960-10 (88044)		EA	2	*	*	1	1	5	22
P O	5210-134-3248	LEVEL ASSEMBLY 890357-1 (02106)		EA	1	*	*	*	*	5	23
X20		PANEL ASSEMBLY, REMOVABLE 890335-3 (02106) (COMPONENTS SAME AS PANEL ASSEMBLY, P/N 890335-1 (02106) EXCEPT WHERE INDIVIDUAL COMPONENTS ARE ANNOTATED)		EA	1					6	1
X20		PANEL ASSEMBLY, REMOVABLE 890335-1 (02106)		EA	1					6	1

(1) SMR CODE	(2) FEDERAL STOCK NUMBER	(3) DESCRIPTION REF NUMBER & MFR CODE	(4) USABLE ON CODE	(5) UNIT OF MEAS QTY INC IN UNIT	(6) 15-DAY ORGANIZATIONAL MAINTENANCE ALW				(7) ILLUS- TRATION	
					(a)	(b)	(c)	(d)	(a)	(b)
					1-5	6-20	21-50	51-100	FIG. NO.	ITEM NO.
P O		SCREW, CAPTIVE: STRIP MTG ZSD06-197-3 (26533)		EA 10	*	*	*	*	6	3
P O	5310-595-5427	WASHER, FLAT: STRIP MTG AN960-416 (88044)		EA 10	REF	REF	REF	REF	6	4
O		RETAINER, WASHER: STRIP MTG 48-41-4-24 (94222)		EA 10					6	6
P O	5305-253-2606	SCREW, THUMB: PLATE MTG 889508-1 (02106) (USE WITH PANEL ASSEMBLY, P/N 890335-1 (02106), ONLY)		EA 10	*	*	1	1	6	15
P O	5410-221-8902	PLATE, CLAMP 889507-1 (02106) (USE WITH PANEL ASSEMBLY, P/N 890335-1 (02106), ONLY)		EA 10	*	*	1	1	6	16
P O	5310-529-6513	WASHER: PLATE MTG 58157C127-156 (79144) (USE WITH PANEL ASSEMBLY, P/N 890335-1 (02106), ONLY)		EA 10	*	*	1	1	6	17
O		SCREW: HINGE MTG MS35224-81 (96906)		EA 2					7	2
O		SCREW: ANTIBACK DRAFT ASSEMBLY MOUNTING MS35224-63 (96906) (USE WITH DOOR ASSEMBLY, P/N 890338-1 (02106), ONLY)		EA 10					7	14
P O	5305-957-7811	SCREW: DOOR STOP MTG MS246935-272 (96906)		EA 3	REF	REF	REF	REF	7	35
P O	5340-780-7183	DOOR STOP		EA 1	REF	REF	REF	REF	7	36
P O	5305-043-2682	SCREW: STRIKER MTG MS24694S98 (96906) (USE WITH DOOR ASSEMBLY, P/N 890338-1 (02106), ONLY)		EA 3	*	*	1	1	7	39
O		SCREW: LOCK ASSEMBLY MTG AN3-4A (88044) (USE WITH DOOR ASSEMBLY, P/N 890338-3 (02106), ONLY)		EA 4					7	55
P O	5310-188-3744	WASHER: LOCK ASSEMBLY MTG MS9320-09 (96906) (USE WITH DOOR ASSEMBLY, P/N 890338-3 (02106), ONLY)		EA 4	*	*	1	1	7	56
P O	5305-267-8977	SCREW: LOCK ASSEMBLY MTG MS90726-10 (96906) (USED WITH DOOR ASSEMBLY, P/N 890338-3 (02106), ONLY)		EA 4	*	*	1	1	7	57
P O	5310-194-0637	WASHER: LOCK MTG MS9320-10 (96906) (USE WITH DOOR ASSEMBLY, P/N 890338-3 (02106), ONLY)		EA 8	REF	REF	REF	REF	7	58
P O		LOCK ASSEMBLY, MODIFIED ZSD18-180-401 (26533) (USE WITH DOOR ASSEMBLY, P/N 890338-3 (02106), ONLY)		EA 1	*	*	*	1	7	59
P O	5315-839-2325	PIN, COTTER MS24665-132 (96906) (USE WITH DOOR ASSEMBLY, P/N 890338-3 (02106), ONLY)		EA 2	*	*	1	1	7	60
P O	5305-269-3235	SCREW: JACK ASSEMBLY MTG MS90727-59 (96906)		EA 22	*	1	1	2	10	4

(1) SMR CODE	(2) FEDERAL STOCK NUMBER	(3) DESCRIPTION REF NUMBER & MFR CODE	(4) USABLE ON CODE	(5) UNIT OF MEAS QTY INC IN UNIT	(6) 15-DAY ORGANIZATIONAL MAINTENANCE ALW				(7) ILLUS- TRATION		
					(a)	(b)	(c)	(d)	(a)	(b)	
					1-5	6-20	21-50	51-100	FIG. NO.	ITEM NO.	
P O	5310-167-0821	WASHER: JACK ASSEMBLY MTG AN960-616 (88044)		EA	16	*	1	1	2	10	5
X20		CONTROL ASSEMBLY, CIRCUIT BREAKER RESET 13217E6815 (60532)		EA	1					10	5
P O	5410-022-2669	JACK ASSEMBLY, MAIN LIFTING 889220-1 (02106)		EA	4					10	6
X20		CORE: END FITTING RESET CONTROL ROD 13217E6817 (60532)		EA	1					10	6
O		SCREW: AIR LOCK ADAPTER MTG MS35234-84 (96906)		EA	9					10	7
X20		KNOB: CIRCUIT BREAKER RESET CONTROL ROD 13217E6816 (60532)		EA	1					10	7
O	5310-176-8121	NUT: AIR LOCK ADAPTER MTG AN354C416 (88044)		EA	9					10	8
X20		CONTROL ASSEMBLY; PUSH PULL, CIRCUIT BREAKER RESET 13217E6815-1 (60532)		EA	1					10	8
P O		CLAMP, AIR LOCK ADAPTER 891780-1 (02106)		EA	9	*	*	1	1	10	9
P O	5310-181-6033	SPACER: CLAMP S8157C127-100 (79144)		EA	9	*	*	*	*	10	10
O		SCREW: LEVEL ASSEMBLY MTG MS24584-57 (96906)		EA	4					11	15
P O	5310-167-0818	WASHER: LEVEL ASSEMBLY MTG AN960-10 (88044)		EA	4	REF	REF	REF	REF	11	16
P O	5210-134-3248	LEVEL ASSEMBLY 890357-1 (02106)		EA	2	REF	REF	REF	REF	11	17
P O		CUP, END 890357-13 (02106)		EA	2	REF	REF	REF	REF	11	18
P O		VIAL, LEVEL 21-8X35 (32868)		EA	1	REF	REF	REF	REF	11	19
P O		SCREW: CLAMP MTG MS35234-84 (96906)		EA	16	REF	REF	REF	REF	12	1
P O	5310-176-8121	NUT: CLAMP MTG AN345C416 (88044)		EA	16	REF	REF	REF	REF	12	2
P O		CLAMP, AIR LOCK ADAPTER 891781-1 (02106)		EA	16	REF	REF	REF	REF	12	3
P O	5310-529-6513	WASHER: CLAMP MTG S8157C127-156 (79144)		EA	16	REF	REF	REF	REF	12	4
O		SCREW: TENSION PLATE AND LEVEL BRACKET MTG NAS1102-5-12 (80205)		EA	24					12	7
P O	5210-134-3248	LEVEL ASSEMBLY 890357-1 (02106)		EA	1	REF	REF	REF	REF	12	15
P O		CUP, END 890357-13 (02106)		EA	2	REF	REF	REF	REF	12	16
P O		VIAL, LEVEL 21-8X35 (32868)		EA	1	REF	REF	REF	REF	12	17

(1) SMR CODE	(2) FEDERAL STOCK NUMBER	(3) DESCRIPTION REF NUMBER & MFR CODE	(4) USABLE ON CODE	(5) QTY INC IN UNIT	(6) 30-DAY DS MAINT ALLOWANCE			(7) 30-DAY GS MAINT ALLOWANCE			(8) 1-YR ALW PER 100 EQUIP CNTGY	(9) ILLUS- TRATION	
					(a)	(b)	(c)	(a)	(b)	(c)		(a)	(b)
					1-20	21-50	51-100	1-20	21-50	51-100		FIG. NO.	ITEM NO.
		SECTION V - REPAIR PARTS FOR DS, GS MAINTENANCE											
		GROUP 01 - AIR LOCK ADAPTER, TIE DOWN ASSEMBLY											
P O		ADAPTER, AIR LOCK 5-4-1630-1 (81337)	EA	1	*	*	*	*	*	*	5	1	1
P F		FRAME ASSEMBLY 5-4-1630-2 (81337)	EA	1	*	*	*	*	*	*	5	1	1
P O		SUPPORT, BOW ASSEMBLY 5-4-1630-3 (81337)	EA	1	*	*	*	*	*	*	5	1	2
M O		LINE, GUY 5-4-1630-11 (81337) MANUFACTURE FROM:	EA	2								1	3
		ROPE, 5/16 IN. DIA BY 13 FT REQUIRED FOR EA LINE, FSN 4020-202-1345											
P O	8340-205-2759	SLIP TENT LINE MILS1734TY11 (81349)	EA	4	*	1	2	*	1	2	24	1	4
P O		BOLT, EYE: 3/8-16 THD SIZE, 2 7/8 IN. LG MS51937-3 (96906)	EA	4	1	1	2	1	1	2	24	1	5
M O		LINE, GUY 5-4-1630-10 (81337) MANUFACTURE FROM:	EA	2								1	6
		ROPE, 5/16 IN. DIA BY 8 FT REQUIRED FOR EA LINE, FSN 4020-202-1345											
P F	5320-619-4093	RIVET: 1/8 IN. DIA, 9/16 IN. LG MS20426AD4-9 (96906) (AS REQUIRED)	EA		1	1	2	1	1	2	24	1	7
P F	5320-117-6844	RIVET: 5/32 IN. DIA, 3/4 IN. LG MS20470AD5-12 (96906)	EA	6	1	1	2	1	1	2	24	1	8
P F	5340-262-4134	RING MILR3390STYLE1 (81349)	EA	4	*	*	1	*	*	1	11	1	9
P F		WEBBING MILW4088TYXV11 (81349) (AS REQUIRED)	YD		1	2	4	1	2	4	48	1	10
P F	5325-264-0823	FASTENER, SLIDE 698720-2 (70167)	EA	1	*	1	2	*	1	2	24	1	11
XI		COVER ASSEMBLY 5-4-1630-4 (81337)	EA	1								1	12
P O	5340-042-8664	STRAP ASSEMBLY 697899-1 (02106)	EA	4	*	*	2	*	*	2	11	2	1
P O	5410-018-7538	NET WEB ASSEMBLY 697899-2 (02106)	EA	1	*	*	*	*	*	*	5	2	2
P O		STRAP ASSEMBLY, CARGO NET 889735-1 (02106)	EA	4	*	*	2	*	*	2	11		
		GROUP 02 - SHELTER BODY ASSEMBLY											
O		SCREW: CLAMP MTG MS35234-84 (96906)	EA	8								3	1
P O	5310-176-8121	NUT: CLAMP MTG AN354C416 (88044)	EA	8	*	1	2	*	1	2	24	3	2

(1) SMR CODE	(2) FEDERAL STOCK NUMBER	(3) DESCRIPTION REF NUMBER & MFR CODE	(4) USABLE ON CODE	(5) UNIT OF MEAS	QTY INC IN UNIT	(6) 30-DAY DS MAINT ALLOWANCE			(7) 30-DAY GS MAINT ALLOWANCE			(8) 1-YR ALW PER 100 EQUIP CNTGY	(9) ILLUS- TRATION	
						(a)	(b)	(c)	(a)	(b)	(c)		(a)	(b)
						1-20	21-50	51-100	1-20	21-50	51-100		FIG. NO.	ITEM NO.
O		CLAMP, AIR LOCK ADAPTER 891781-1 (02106)	EA	8									3	3
P O	5310-529-6513	WASHER: CLAMP MTG 58157C127-156 (79144)	EA	8	*	1	2	*	1	2	24		3	4
P O		SCREW, SHOULDER: SUPPORT MTG 12705L8c8c (56878)	EA	2	2	2	2	2	2	2	24		3	5
P O	5310-167-0823	WASHER: SUPPORT MTG AN960-816 (88044)	EA	2	*	1	2	*	1	2	24		3	6
P O	5306-838-7487	SCREW: CLIP MTG NAS1105-4 (80205)	EA	2	*	1	2	*	1	2	24		3	7
P O	5360-251-4006	SPRING, : CABLE STOWAGE ZSD14-194 (26533)	EA	2	*	1	2	*	1	2	20		3	8
P O		CLIP, SPRING RETAINER ZSD06-195 (26533)	EA	2	*	1	2	*	1	2	20		3	9
P O		SCREW, SHOULDER: CABLE ASSEMBLY MOUNTING 12705L8c8c (56878)	EA	2	REF	REF	REF	REF	REF	REF	REF		3	10
P O	5310-167-0823	WASHER: CABLE ASSEMBLY MTG AN960-816 (88044)	EA	2	REF	REF	REF	REF	REF	REF	REF		3	11
P O	5410-522-2475	CABLE ASSEMBLY, FLOOR SUPPORT 890360-1 (02106)	EA	2	*	*	1	*	*	1	10		3	12
O		NUT: SUPPORT MTG MS20365-624 (96906)	EA	2									3	13
P O	5306-144-4004	BOLT: SUPPORT MTG AN6-12A (88044)	EA	2	*	1	2	*	1	2	20		3	14
P O	5340-067-9884	BODY, TURNBUCKLE MS21251-8L (96906)	EA	2	*	*	1	*	*	1	11		3	15
P O	5410-522-2481	SUPPORT ASSEMBLY FOLDING ROOF 890359-2 (02106) (COMPONENTS SAME AS SUPPORT ASSEMBLY, P/N 890359-1 (02106))	EA	1	*	*	1	*	*	1	10			
P O	5410-522-2480	SUPPORT ASSEMBLY FOLDING ROOF 890359-1 (02106)	EA	1	*	*	1	*	*	1	10			
P F		SUPPORT ASSEMBLY 890359-4 (02106) (COMPONENTS SAME AS SUPPORT ASSEMBLY, P/N 890359-3 (02106))	EA	1	*	*	*	*	*	*	5			
P F		SUPPORT ASSEMBLY 890359-3 (02106)	EA	1	*	*	*	*	*	*	5			
P F	5340-811-6643	RING 5133-50 (79136)	EA	1	1	1	2	1	1	2	24		3	16
P F	5320-117-6950	RIVET: SUPPORT AND PLATE MTG MS20426AD4-5 (96906)	EA	3	1	1	2	1	1	2	24		3	17
P F		PIN ASSEMBLY 50603S4RO4L6 (84256)	EA	1	1	1	2	1	1	2	24		3	18
P O		BOLT, SHOULDER: SUPPORT MTG, 1/2 IN. DIA X 1/2 IN. LG CL4SS (99862)	EA	1	1	1	2	1	1	2	24		3	19
P O	5310-167-0839	WASHER, LOCK: SUPPORT MTG AN960-816L (88044)	EA	2	1	1	2	1	1	2	24		3	20
P O		BOLT, SHOULDER: SUPPORT MTG, 1/2 IN. DIA X 3/4 IN. LG CL32SS (99862)	EA	1	1	1	2	1	1	2	24		3	21
P F		BOLT: BRACKET MTG AN4-6A (88044)	EA	2	1	1	2	1	1	2	24		3	22
P F	5310-167-0667	WASHER, LOCK: BRACKET MTG AN935-416L (88044)	EA	2	1	1	2	1	1	2	24		3	23

(1) SMR CODE	(2) FEDERAL STOCK NUMBER	(3) DESCRIPTION REF NUMBER & MFR CODE	(4) USABLE ON CODE	(5) UNIT OF MEAS	(6) 30-DAY DS MAINT ALLOWANCE	(7) 30-DAY GS MAINT ALLOWANCE			(8) 1-YR ALW PER 100 EQUIP CNTGY	(9) ILLUS- TRATION				
						(a)	(b)	(c)		(a)	(b)	(c)	(a)	(b)
						1-20	21-50	51-100		1-20	21-50	51-100	FIG. NO.	ITEM NO.
P F		BRACKET 890359-15 (02106)		EA	1	*	*	*	*	*	*	5	3	24
P F		PLATE 890359-17 (02106)		EA	1	*	*	*	*	*	*	5	3	25
P F		INSERT: SUPPORT MTG Z5D03-189-1 (26533)		EA	2	1	1	2	1	1	2	24	3	26
P F	5320-956-7355	RIVET: STRIKER MTG MILR24243-6A604H (81349)		EA	24	1	1	3	1	1	3	30	3	27
P F	5325-550-4360	STRIKER, LINK LOCK N02 (82240)		EA	8	*	*	1	*	*	1	10	3	28
M F		DOUBLER 890331-29 (02106) MANUFACTURE FROM: SHEET, .125 IN. BY 9/16 IN. BY 2 IN. REQUIRED FOR EA DOUBLER, P/N QQA250-11 (81348)		EA	8								3	29
F		SCREW: PLATE MTG NAS1155-11 (80205)		EA	6								3	30
M F		PLATE, COVER SHEAR 890358-1 (02106) MANUFACTURE FROM: SHEET, .25 IN. BY 3 1/2 IN. BY 1 1/4 IN. REQUIRED FOR EA PLATE, P/N C101825THK (81348)		EA	2								3	31
XI		PLATE, FILLER 890364-1 (02106)		EA	2								3	32
P F		PLATE, SHEAR 890353-1 (02106)		EA	2	*	*	*	*	*	*	5	3	33
P O	5410-522-2479	POST, CORNER 890363-1 (02106)		EA	2	*	1	1	*	1	1	16	3	34
X2F		PLUG, LOCATION 890363-13 (02106)		EA	1									
X2F		PLUG 890363-15 (02106)		EA	1									
X2F		PLUG, LOCATION 890363-17 (02106)		EA	1									
X2F		HANDLE 890363-19 (02106)		EA	1									
F		SCREW, DRIVE: NO. 8 X .375 IN. LG TYPEU (45722)		EA	4									
F		SPRING, COMPRESSOR MS24585-1294 (96906)		EA	1									
P F	5305-067-9850	SCREW: ANGLE MTG MS24693S122 (96906)		EA	96	1	1	2	1	1	2	24	3	35
P F	5320-882-8388	RIVET: ANGLE MTG MILR24243-6A403H (81349)		EA	48	1	2	4	1	2	4	48	3	36
P F	5320-882-8388	RIVET MILR24243-6A403H (81349)		EA	72	REF	REF	REF	REF	REF	REF	REF	3	36
M F		ANGLE, CORNER BRACE 890331-21 (02106) MANUFACTURE FROM: ANGLE, 1 1/2 IN. BY 1 1/2 IN. BY 1 3/2 IN. REQUIRED FOR EA ANGLE, P/N QQA200-8 (81348)		EA	12								3	37
O		SCREW: BRACKET MTG AN520C10R10 (88044)		EA	16								3	38
P O	5310-167-0812	WASHER: BRACKET MTG AN960C10L (88044)		EA	16	1	1	2	1	1	2	24	3	39

(1) SMR CODE	(2) FEDERAL STOCK NUMBER	(3) DESCRIPTION USABLE ON CODE	(4) UNIT OF MEAS	(5) QTY INC IN UNIT	(6) 30-DAY DS MAINT ALLOWANCE			(7) 30-DAY GS MAINT ALLOWANCE			(8) 1-YR ALW PER 100 EQUIP CNTGY	(9) ILLUS- TRATION	
					(a)	(b)	(c)	(a)	(b)	(c)		(a) FIG. NO.	(b) ITEM NO.
					1-20	21-50	51-100	1-20	21-50	51-100			
X20		BRACKET, STRAP CARGO NET 889751-1 (02106)	EA	8								3	40
P O		FABRIC ENCLOSURE ASSEMBLY 890340-1 (02106)	EA	1	*	*	*	*	*	*	5	3	41
P F	5325-619-0843	STUD XB78332 (61864)	EA	18	1	2	4	1	2	4	48	3	42
P F	5325-281-8643	EYELET BS78403 (61864)	EA	18	1	2	4	1	2	4	48	3	43
P F	5325-281-4782	WASHER BS78505 (61864)	EA	18	1	2	4	1	2	4	48	3	44
P F	5325-371-8109	CLINCH PLATE BS78507 (61864)	EA	18	1	2	4	1	2	4	48	3	45
P O	5410-221-8901	PLUG ASSEMBLY 890340-7 (02106)	EA	2	*	*	1	*	*	1	10	3	46
M F		HOOK 890340-89 (02106) MANUFACTURE FROM: TAPE, 1 IN. BY 25 IN. REQUIRED FOR EA HOOK, FSN 8315-935-6721	EA	16								3	47
M F		FLAP ASSEMBLY 890340-9 (02106) MANUFACTURE FROM: HOOK, 1 IN. BY 26 IN. REQUIRED FOR EA FLAP ASSEMBLY, FSN 8315-935-6721 PILE, 1 IN. BY 25 IN. REQUIRED FOR EA FLAP ASSEMBLY, FSN 8315-926-4930	EA	2								3	48
M F		SCREEN ASSEMBLY 890340-11 (02106) MANUFACTURE FROM: TAPE, 1 IN. BY 26 IN. REQUIRED FOR EA SCREEN ASSEMBLY, FSN 8315-935-6721 PILE, 1 IN. BY 25 IN. REQUIRED FOR EA SCREEN ASSEMBLY, FSN 8315-926-4930 NETTING, 26 IN. BY 26 IN. REQUIRED FOR EA SCREEN ASSEMBLY, FSN 8305-926-1613	EA	2								3	49
M F		PILE 890340-83 (02106) MANUFACTURE FROM: PILE, 1 IN. BY 26 IN. REQUIRED, FSN 8315-926-4930	EA	1								3	50
F		RIVET: KEEPER PLATE MTG AD868S (07707)	EA	4								3	51
X2F		PLATE, KEEPER HS250-495 (98003)	EA	4								3	52
P F	5320-143-6149	RIVET: SPACER MTG MILLR24243-7A403H (81349)	EA	8	1	1	2	1	1	2	24	3	53
M F		SPACER 890340-59 (02106) MANUFACTURE FROM: SHEET, .090 IN. BY 3/4 IN. BY 2 1/4 IN. REQUIRED FOR EA SPACER, P/N QQA250-4 (81348)	EA	4								3	54

(1) SMR CODE	(2) FEDERAL STOCK NUMBER	(3) DESCRIPTION REF NUMBER & MFR CODE	(4) USABLE ON CODE	(5) QTY INC IN UNIT	(6) 30-DAY DS MAINT ALLOWANCE			(7) 30-DAY GS MAINT ALLOWANCE			(8) 1-YR ALW PER 100 EQUIP CNTGY	(9) ILLUS- TRATION	
					(a)	(b)	(c)	(a)	(b)	(c)		(a)	(b)
					1-20	21-50	51-100	1-20	21-50	51-100		FIG. NO.	ITEM NO.
M F		EXTRUSION 890340-80 (02106) MANUFACTURE FROM: EXTRUSION, 29 IN. REQUIRED FOR EA EXTRUSION, P/N ZSD01-193 (26533)	EA	2								3	55
P F	5320-882-8385	RIVET: LINK LOCK MTG MILR24243-6A606H (81349)	EA	32	1	2	4	1	2	4	48	3	56
P F	5325-550-4360	LINK LOCK N02 (82240)	EA	8	*	*	1	*	*	1	10	3	57
P F		SPACER: LINK LOCK MTG 890340-121 (02106)	EA	8	*	*	*	*	*	*	5	3	58
P F		SPACER: LINK LOCK MTG 890340-119 (02106)	EA	8	*	*	*	*	*	*	5	3	59
M F		EXTRUSION 890340-77 (02106) MANUFACTURE FROM: EXTRUSION, 3 FT 6 IN. REQUIRED, P/N ZSD01-193 (26533)	EA	1								3	60
M F		EXTRUSION 890340-78 (02106) MANUFACTURE FROM: EXTRUSION, 3 FT 6 IN. REQUIRED, P/N ZSD01-193 (26533)	EA	1								3	60
P F	5320-117-6949	RIVET: STRIP MTG MS20426AD4-4 (96906)	EA	20	1	2	4	1	2	4	48	3	61
M F		FOAM 890340-63 (02106) MANUFACTURE FROM: FOAM, 1 IN. X 3 FT 9 IN. BY 12 FT REQUIRED, P/N MILP26514 (81349)	EA	1								3	62
M F		FOAM 890340-67 (02106) MANUFACTURE FROM: FOAM, 1 IN. BY 3 FT 9 IN. BY 3 FT 1 IN. REQUIRED FOR EA FOAM, P/N MILP26514 (81349)	EA	2								3	62
M F		FOAM 890340-17 (02106) MANUFACTURE FROM: FOAM, 1 IN. BY 1 5/16 IN. BY 3 FT 9 IN. REQUIRED FOR EA FOAM, P/N MILP26514 (81349)	EA	4								3	62
P F		ZIPPER VF106TY4STYLE8SIZEH220INLG (81348)	EA	1	1	2	4	1	2	4	48	3	63
X2F		ROPE 890340-81 (02106)	EA	20								3	64
M F		WEBBING 890340-53 (02106) MANUFACTURE FROM: WEBBING, .045 IN. BY 1 IN. BY 8 1/2 IN. REQUIRED FOR EA WEBBING, FSN 8305-260-6906	EA	27									
M F		PILE 890340-91 (02106) MANUFACTURE FROM: PILE, 1 IN. BY 4 IN. REQUIRED FOR EA PILE, FSN 8315-926-4930	EA	2									

(1) SMR CODE	(2) FEDERAL STOCK NUMBER	(3) DESCRIPTION USABLE ON CODE REF NUMBER & MFR CODE	(4) UNIT OF MEAS	(5) QTY INC IN UNIT	(6) 30-DAY DS MAINT ALLOWANCE			(7) 30-DAY GS MAINT ALLOWANCE			(8) 1-YR ALW PER 100 EQUIP CNTGY	(9) ILLUS- TRATION	
					(a)	(b)	(c)	(a)	(b)	(c)		(a)	(b)
					1-20	21-50	51-100	1-20	21-50	51-100		FIG. NO.	ITEM NO.
M F		STRAP 890340-123 (02106) MANUFACTURE FROM:	EA	2									
P F	5340-042-8683	WEBBING, .025 IN. BY .56 IN. BY 6 IN. REQUIRED FOR EA STRAP, FSN 8305-260-6929											
P F		MUT: SUPPORT MTG BN528-428-3-24 (73197)	EA	4	1	1	2	1	1	2	24	3	65
P F		INSERT: CLAMP SCREW ZSD03-169-1 (26533)	EA	24	1	1	2	1	1	2	24		
M F		FILLER 890340-61 (02106) MANUFACTURE FROM:	EA	2									
X2F		PHENOLIC, 1/4 IN. BY 3/4 IN. BY 7/8 IN. REQUIRED FOR EA FILLER, FSN 9330-180-9641											
X2F		PANEL ASSEMBLY, ROOF FOLDING 890337-1 (02106)	EA	1								4	1
M F		PIN: HINGE MTG MS20253P5-1390 (96906) MANUFACTURE FROM:	EA	1								4	2
P F	5320-486-8251	ROD, 11 FT 7 IN. REQUIRED, FSN 5315-110-5582											
P F		RIVET: HINGE MTG MILR24243-7A602H (81349)	EA	83	1	2	4	1	2	4	48	4	3
P F	5305-781-5690	SCREW: HINGE MTG MS24693S94 (96906)	EA	14	REF	REF	REF	REF	REF	REF	REF	4	4
P F	5320-420-2165	RIVET: EXTRUSION MTG MILR24243-7A604H (81349)	EA	88	1	2	4	1	2	4	48	4	5
P F	5340-236-8352	HINGE, HALF 890356-3 (02106)	EA	1	*	1	2	*	1	2	20	4	6
M F		CLOSEOUT 890337-21 (02106) MANUFACTURE FROM:	EA	1								4	7
M F		SHEET, .12 IN. BY 2.10 IN. BY 12 FT REQUIRED, P/N MILP3155 (81349)											
M F		STRIP 890331-17 (02106) MANUFACTURE FROM:	EA	1								4	8
M F		SHEET, .063 IN. BY 1/2 IN. BY 12 FT REQUIRED, P/N QQA250-11 (81348)											
M F		SEAL 890331-19 (02106) MANUFACTURE FROM:	EA	1								4	9
M F		SEAL, 12 FT 2 IN. REQUIRED, FSN 5330-105-8667											
M F		CHANNEL 890332-27 (02106) MANUFACTURE FROM:	EA	2								4	10
P F	5320-117-6953	CHANNEL, .125 IN. BY 1 IN. BY 1 1/2 IN. REQUIRED FOR EA CHANNEL, P/N QQA250-11 (81349)											
X2F		RIVET: CASTING MTG MS20426AD4-8 (96906)	EA	2	*	1	2	*	1	2	20	4	11
X2F		CASTING 890337-19 (02106)	EA	2								4	12

(1) SMR CODE	(2) FEDERAL STOCK NUMBER	(3) DESCRIPTION REF NUMBER & MFR CODE	(4) USABLE ON CODE	(5) UNIT OF MEAS	(6) 30-DAY DS MAINT ALLOWANCE	(7) 30-DAY GS MAINT ALLOWANCE			(8) 1-YR ALW PER 100 EQUIP CNTGY	(9) ILLUS- TRATION				
						(a)	(b)	(c)		(a)	(b)	(c)	(a)	(b)
						1-20	21-50	51-100		1-20	21-50	51-100	FIG. NO.	ITEM NO.
P F	5305-891-1783	SCREW: PLATE MTG MS27039-4-10 (96906)	EA	4	1	1	2	1	1	2	24	4	13	
P F	5310-167-0667	WASHER, LOCK: PLATE MTG AN935-416L (88044)	EA	4	1	1	2	1	1	2	24	4	14	
X2F		PLATE HS250-395 (98003)	EA	2								4	15	
P F	5320-956-7355	RIVET: EXTRUSION MTG MILR24243-6A604H (81349)	EA	18	REF	REF	REF	REF	REF	REF	REF	4	16	
X2F		EXTRUSION 890337-16 (02106)	EA	1								4	17	
X2F		EXTRUSION 890337-15 (02106)	EA	1								4	18	
P F	5320-882-8385	RIVET: EXTRUSION MTG MILR24243-6A606H (81349)	EA	26	REF	REF	REF	REF	REF	REF	REF	4	19	
X2F		EXTRUSION 890337-17 (02106)	EA	1								4	20	
M F		SPACER 890337-11 (02106) MANUFACTURE FROM: SHEET, .188 IN. BY 1 IN. BY 11 FT 3 IN. REQUIRED, P/N QQA250-4 (81348)	EA	1								4	21	
M F		SPACER 890337-23 (02106) MANUFACTURE FROM: SHEET, .06 IN. BY 1 IN. BY 2 IN. REQUIRED FOR EA SPACER, P/N QQA250-11 (81348)	EA	2								4	22	
P F	5320-882-8388	RIVET: BRACKET ASSEMBLY MTG MILR24243-6A403H (81349)	EA	12	REF	REF	REF	REF	REF	REF	REF	4	23	
M F		BRACKET ASSEMBLY, SLIDE 891782-6 (02106) MANUFACTURE FROM: RAIL, .063 IN. BY .88 IN. BY 4 IN. REQUIRED FOR EA BRACKET ASSEMBLY, P/N QQA250-11 (81348) SPACER, .080 IN. BY 1/2 IN. BY 3 1/2 IN. REQUIRED FOR EA BRACKET ASSEMBLY, P/N QQA250-11 (81348) RIVET, 1 EA REQUIRED FOR EA BRACKET ASSEMBLY, FSN 5320-117-6826	EA	2									4	24
M F		BRACKET ASSEMBLY, SLIDE 891782-5 (02106) MANUFACTURE FROM: RAIL, .063 IN. BY .88 IN. BY 4 IN. REQUIRED FOR EA BRACKET ASSEMBLY, P/N QQA250-11 (81348) SPACER, .080 IN. BY 1/2 IN. BY 3 1/2 IN. REQUIRED FOR EA BRACKET ASSEMBLY, P/N QQA250-11 (81348) RIVET, 1 EA REQUIRED FOR EA BRACKET ASSEMBLY, FSN 5320-117-6826	EA	2									4	25
P F	5306-531-8979	BOLT: ANGLE MTG AN6-7A (88044)	EA	8	1	1	2	1	1	2	24	4	26	
P F	5310-167-0672	WASHER, LOCK: ANGLE MTG AN935-616L (88044)	EA	8	1	1	2	1	1	2	24	4	27	
X2F		ANGLE, SHEAR 890354-1 (02106)	EA	2								4	28	

(1) SMR CODE	(2) FEDERAL STOCK NUMBER	(3) DESCRIPTION REF NUMBER & MFR CODE	(4) USABLE ON CODE	(5) UNIT OF MEAS	QTY INC IN UNIT	(6) 30-DAY DS MAINT ALLOWANCE			(7) 30-DAY GS MAINT ALLOWANCE			(8) 1-YR ALW PER 100 EQUIP CNTGY	(9) ILLUS- TRATION	
						(a)	(b)	(c)	(a)	(b)	(c)		(a)	(b)
						1-20	21-50	51-100	1-20	21-50	51-100			
P F	5325-276-4930	FASTENER, SNAP MS27900-13N (96906)		EA	3	1	1	2	1	1	2	24	4	29
X2F		CUP ZR14-6 (26533)		EA	2								4	30
P O	5306-150-9105	BOLT; HANDLE MTG AN4-4A (88044)		EA	8	1	1	2	1	1	2	24	4	31
P O	5310-595-5427	WASHER, FLAT; HANDLE MTG AN960-416 (88044)		EA	8	1	1	2	1	1	2	24	4	32
X20		HANDLE ASSEMBLY ZSP3-003-2 (26533)		EA	2								4	33
P F		INSERT; HANDLE MTG ZSD03-189-3 (26533)		EA	8	1	1	2	1	1	2	24	4	34
P F		INSERT; ANGLE MTG ZSD03-102-9 (26533)		EA	8	1	1	2	1	1	2	24	4	35
P F		INSERT; HINGE MTG ZSD03-169-1 (26533)		EA	14	REF	REF	REF	REF	REF	REF	REF	4	36
X2F		NUT, BLIND RIVET; SNAP MTG NAS1329AC8875 (80205)		EA	3									
X2F		FLOOR PANEL ASSEMBLY 890336-1 (02106)		EA	1								5	1
M F		PIN, HINGE MS20253P5-1390 (96906) MANUFACTURE FROM: ROD, 11 FT 7 IN. REQUIRED, FSN 5315-110-5582		EA	1								5	2
P F	5320-420-2165	RIVET; CASTING AND HINGE MTG MILR24243-7A604H (81349)		EA	116	REF	REF	REF	REF	REF	REF	REF	5	3
P F	5305-781-5690	SCREW; HINGE MTG MS24693594 (96906)		EA	14	REF	REF	REF	REF	REF	REF	REF	5	4
P F	5320-486-8251	RIVET; STRIP MTG MILR24243-7A602H (81349)		EA	33	REF	REF	REF	REF	REF	REF	REF	5	5
P F	5340-236-8352	HINGE; HALF 890356-3 (02106)		EA	1	REF	REF	REF	REF	REF	REF	REF	5	6
M F		CLOSEOUT 890336-21 (02106) MANUFACTURE FROM: SHEET, .12 IN. BY 2 1/4 IN. BY 12 FT REQUIRED, P/N MILP3155 (81349)		EA	1								5	7
M F		STRIP 890331-17 (02106) MANUFACTURE FROM: SHEET, .063 IN. BY 1/2 IN. BY 12 FT REQUIRED, P/N QQA250-11 (81348)		EA	1								5	8
M F		SEAL 890331-19 (02106) MANUFACTURE FROM: SEAL, 12 FT 2 IN. REQUIRED, FSN 5330-105-8667		EA	1								5	9
P F	5306-151-1426	BOLT; ANGLE MTG AN4-6A (88044)		EA	4	REF	REF	REF	REF	REF	REF	REF	5	10
P F	5310-595-5427	WASHER, FLAT; ANGLE MTG AN960-416 (88044)		EA	4	REF	REF	REF	REF	REF	REF	REF	5	11

(1) SMR CODE	(2) FEDERAL STOCK NUMBER	(3) DESCRIPTION REF NUMBER & MFR CODE	(4) UNIT OF MEAS	(5) QTY INC IN UNIT	(6) 30-DAY DS MAINT ALLOWANCE			(7) 30-DAY GS MAINT ALLOWANCE			(8) 1-YR ALW PER 100 EQUIP CNTGY	(9) ILLUS- TRATION	
					(a)	(b)	(c)	(a)	(b)	(c)		(a)	(b)
					1-20	21-50	51-100	1-20	21-50	51-100		FIG. NO.	ITEM NO.
M F		ANGLE 890336-11 (02106) MANUFACTURE FROM: ANGLE, 1.25 IN. BY 1.25 IN. BY .25 IN. REQUIRED FOR EA ANGLE, P/N QQA200-8 (81348)	EA	2								5	12
P F	5305-891-1783	SCREW: PLATE MTG MS27039-4-10 (96906)	EA	4	REF	REF	REF	REF	REF	REF	REF	5	13
P F	5310-167-0667	WASHER, LOCK: PLATE MTG AN935-416L (88044)	EA	4	REF	REF	REF	REF	REF	REF	REF	5	14
X2F		PLATE HS250-39S (98003)	EA	2								5	15
P F		CASTING 890336-19 (02106)	EA	2	*	*	*	*	*	*	5	5	16
P F	5320-956-7355	RIVET: EXTRUSION MTG MILR24243-6A604H (81349)	EA	12	REF	REF	REF	REF	REF	REF	REF	5	17
P F		EXTRUSION 890336-15 (02106)	EA	1	*	*	*	*	*	*	2	5	18
P F		EXTRUSION 890336-17 (02106)	EA	1	*	*	*	*	*	*	2	5	19
P F		EXTRUSION 890336-16 (02106)	EA	1	*	*	*	*	*	*	2	5	20
O		SCREW: LEVEL ASSEMBLY MTG MS24584-57 (96906)	EA	2								5	21
P O	5310-167-0818	WASHER: LEVEL ASSEMBLY MTG AN960-10 (88044)	EA	2	1	1	2	1	1	2	24	5	22
P O	5210-134-3248	LEVEL ASSEMBLY 890357-1 (02106)	EA	1	*	*	*	*	*	*	5	5	23
X2F		BOX ASSEMBLY ZSD16-181-1 (26533)	EA	1								5	24
P F	5310-917-6086	NUT SS10KB80 (26533)	PC	2	1	1	2	1	1	2	24	5	25
P F	5306-531-8979	BOLT: ANGLE MTG AN6-7A (88044)	EA	8	REF	REF	REF	REF	REF	REF	REF	5	26
F	5310-167-0672	WASHER, LOCK: ANGLE MTG AN935-616L (88044)	EA	8								5	27
M F		ANGLE, SHEAR 890354-1 (02106) MANUFACTURE FROM: ANGLE, 3/8 IN. BY 3 IN. BY 2 IN. REQUIRED FOR EA ANGLE, P/N ASTMA7-52T (81348)	EA	2								5	28
P F	5320-490-2238	RIVET: STRIP MTG MILR24243-6A503H (81349)	EA	58	1	2	4	1	2	4	48	5	29
P F		RUBBING STRIP ZSD01-113-3 (26533)	EA	1	*	*	*	*	*	*	5	5	30
X2F		CUP ZR14-6 (26533)	EA	2								5	31
P F		INSERT: ANGLE MTG ZSD03-102-9 (26533)	EA	8	REF	REF	REF	REF	REF	REF	REF	5	32
P F		INSERT: HINGE AND PLATE MTG ZSD03-169-1 (26533)	EA	18	REF	REF	REF	REF	REF	REF	REF	5	33
P F		INSERT, POTTED: ANGLE MTG ZSD03-189-1 (26533)	EA	2	REF	REF	REF	REF	REF	REF	REF	5	34
P F		INSERT, POTTED: ANGLE MTG ZSD03-191 (26533)	EA	4	1	1	2	1	1	2	24	5	35

(1) SMR CODE	(2) FEDERAL STOCK NUMBER	(3) DESCRIPTION REF NUMBER & MFR CODE	(4) USABLE ON CODE	(5) QTY INC IN UNIT	(6) 30-DAY DS MAINT ALLOWANCE			(7) 30-DAY GS MAINT ALLOWANCE			(8) 1-YR ALW PER 100 EQUIP CNTGY	(9) ILLUS- TRATION	
					(a)	(b)	(c)	(a)	(b)	(c)		(a) FIG. NO.	(b) ITEM NO.
					1-20	21-50	51-100	1-20	21-50	51-100			
X20		PANEL ASSEMBLY, REMOVABLE 890335-3 (02106) (COMPONENTS SAME AS PANEL ASSEMBLY, P/N 890335-1 (02106) EXCEPT WHERE INDIVIDUAL COMPONENTS ARE ANNOTATED)	EA	1								6	1
X20		PANEL ASSEMBLY, REMOVABLE 890335-1 (02106)	EA	1								6	1
P F	5320-956-7355	RIVET: STRIP MTG MILR24243-6A604H (81349)	EA	44	REF	REF	REF	REF	REF	REF	REF	6	2
P O		SCREW, CAPTIVE: STRIP MTG ZSD06-197-3 (26533)	EA	10	*	*	1	*	*	1	11	6	3
P O	5310-595-5427	WASHER, FLAT: STRIP MTG AN960-416 (88044)	EA	10	REF	REF	REF	REF	REF	REF	REF	6	4
M F		ATTACH STRIP 890361-1 (02106) MANUFACTURE FROM: SHEET, .09 IN. BY 2 1/4 IN. BY 5 FT 6 IN. REQUIRED FOR EA STRIP, P/N QQA250-11 (81348)	EA	2								6	5
O		RETAINER, WASHER: STRIP MTG 48-41-4-24 (94222)	EA	10								6	6
M F		PHENOLIC CLOSEOUT 890335-21 (02106) MANUFACTURE FROM: SHEET, 2 1/4 IN. BY 4 FT 2 IN. REQUIRED FOR EA CLOSEOUT, FSN 9330-180-9642	EA	2								6	7
M F		PHENOLIC CLOSEOUT 890335-19 (02106) MANUFACTURE FROM: SHEET, 2 1/4 IN. BY 6 FT 1 IN. REQUIRED FOR EA CLOSEOUT, FSN 9330-180-9642	EA	2								6	8
P F	5320-932-1972	RIVET: PLATE ASSEMBLY MTG MILR24243-6A402H (81349)	EA	24	1	2	4	1	2	4	24	6	9
X2F		PLATE ASSEMBLY, HANDLE 890335-5 (02106)	EA	2								6	10
M F		GASKET: DOOR 890335-15 (02106) MANUFACTURE FROM: SHEET, 3/16 IN. BY 2 IN. BY 4 FT 2 IN. REQUIRED, P/N MILP6855 (81349)	EA	1								6	11
P F	5320-932-1972	RIVET: STRIP MTG MILR24243-6A402H (81349)	EA	33	REF	REF	REF	REF	REF	REF	REF	6	12
M F		STRIP: DOOR 890335-13 (02106) MANUFACTURE FROM: SHEET, .040 IN. BY 1/2 IN. BY 4 FT 1 IN. REQUIRED, P/N QQA250-11 (81348)	EA	1								6	13
M F		SEAL BULB 890335-27 (02106) MANUFACTURE FROM: SEAL, 4FT 2 IN. REQUIRED, FSN 5330-105-6886	EA	1								6	14
P O	5305-253-2606	SCREW, THUMB: PLATE MTG 889508-1 (02106) (USE WITH PANEL ASSEMBLY, P/N 890335-1 (02106), ONLY)	EA	10	1	1	2	1	1	2	24	6	15

(1) SMR CODE	(2) FEDERAL STOCK NUMBER	(3) DESCRIPTION USABLE CN CODE REF NUMBER & MFR CODE	(4) UNIT OF MEAS	(5) QTY INC IN UNIT	(6) 30-DAY DS MAINT ALLOWANCE			(7) 30-DAY GS MAINT ALLOWANCE			(8) 1-YR ALW PER 100 EQUIP CNTGY	(9) ILLUS- TRATION	
					(a)	(b)	(c)	(a)	(b)	(c)		(a)	(b)
					1-20	21-50	51-100	1-20	21-50	51-100		FIG. NO.	ITEM NO.
P O	5410-221-8902	PLATE, CLAMP 89507-1 (02106) (USE WITH PANEL ASSEMBLY, P/N 890335-1 (02106), ONLY)	EA	10	1	1	2	1	1	2	24	6	16
P O	5310-529-6513	WASHER: PLATE MTG S8157C127-156 (79144) (USE WITH PANEL ASSEMBLY, P/N 890335-1 (02106), ONLY)	EA	10	1	1	2	1	1	2	24	6	17
X2F		PANEL ASSEMBLY, PLUG 890339-1 (02106) (USE WITH PANEL ASSEMBLY, P/N 890335-1 (02106), ONLY)	EA	1								6	18
P F	5320-882-8388	RIVET: PLATE MTG M1LR24243-6A403H (81349)	EA	16	REF	REF	REF	REF	REF	REF	REF	6	19
X1		PANEL 890335-11 (02106) (USE WITH PANEL ASSEMBLY, P/N 890335-1 (02106), ONLY)	EA	1								6	20
X1		PLATE 890339-13 (02106)	EA	1								6	21
X1		STRIP 890339-15 (02106)	EA	2								6	22
X1		STRIP 890339-17 (02106)	EA	2								6	23
M F		GASKET 890339-19 (02106) MANUFACTURE FROM: RUBBER, .13 IN. BY 1 IN. BY 22 IN. REQUIRED BY EA GASKET, P/N AMS3195 (81343)	EA	2								6	24
M F		GASKET 890339-21 (02106) MANUFACTURE FROM: RUBBER, .13 IN. BY 1 IN. BY 12 IN. REQUIRED FOR EA GASKET, P/N AMS3195 (81343)	EA	2								6	25
X1		PHENOLIC CLOSEOUT 890339-25 (02106)	EA	2								6	26
X1		PHENOLIC, CLOSEOUT 890339-23 (02106)	EA	2								6	27
M F		PHENOLIC CLOSEOUT 890335-25 (02106) MANUFACTURE FROM: SHEET, 3 IN. BY 13 1/2 IN. REQUIRED FOR EA CLOSEOUT, FSN 9330-180-9642 (USE WITH PANEL ASSEMBLY, P/N 890335-1 (02106), ONLY)	EA	2								6	28
M F		PHENOLIC CLOSEOUT 890335-23 (02106) MANUFACTURE FROM: SHEET, 3 IN. BY 20 1/2 IN. REQUIRED FOR EA CLOSEOUT, FSN 9330-180-9642 (USE WITH PANEL ASSEMBLY, P/N 890335-1 (02106), ONLY)	EA	2								6	29
P F	5325-276-4930	FASTENER, SNAP MS27980-13N (96906)	EA	3	REF	REF	REF	REF	REF	REF	REF	6	30
X2F		NUT, BLIND RIVET: SNAP MTG NAS1329A08B75 (80205)	EA	3								6	31

(1) SMR CODE	(2) FEDERAL STOCK NUMBER	(3) DESCRIPTION REF NUMBER & MFR CODE	(4) USABLE ON CODE	(5) UNIT OF MEAS	(6) 30-DAY DS MAINT ALLOWANCE	(7) 30-DAY GS MAINT ALLOWANCE	(8) 1-YR ALW PER 100 EQUIP CNTGY	(9) ILLUS- TRATION							
								(a)			(b)			(a)	(b)
								1-20	21-50	51-100	1-20	21-50	51-100	FIG. NO.	ITEM NO.
P F		INSERT: PLATE MTG ZSD03-169-1 (26533) (USE WITH PANEL ASSEMBLY, P/N 890335-1 (02106), ONLY)		EA	10	REF	REF	REF	REF	REF	REF	6	32		
P F		DOOR ASSEMBLY, ACCESS 890338-3 (02106) (COMPONENTS SAME AS DOOR ASSEMBLY, P/N 890338-1 (02106) EXCEPT WHERE INDIVIDUAL COMPONENTS ARE ANNOTATED)		EA	1	*	*	*	*	*	*	5	7 1		
P F		DOOR ASSEMBLY, ACCESS 890338-1 (02106)		EA	1	*	*	*	*	*	*	3	7 1		
O		SCREW: HINGE MTG MS35224-81 (96906)		EA	2								7 2		
P F	5320-956-7355	RIVET: LOCK ASSEMBLY, HINGE MTG MILR24243-6A604H (81349)		EA	46	REF	REF	REF	REF	REF	REF	REF	7 3		
P F	5305-993-2461	SCREW, CAPTIVE: HINGE MTG ZSD06-1973 (02106)		EA	5	*	*	1	*	*	1	11	7 4		
P F	5310-595-5427	WASHER, FLAT: HINGE MTG AN960-416 (88044)		EA	5	REF	REF	REF	REF	REF	REF	REF	7 5		
P F		RETAINER WASHER: HINGE MTG 48-41-4-24 (94222)		EA	5	REF	REF	REF	REF	REF	REF	REF	7 6		
P F	5340-022-3167	HINGE ASSEMBLY, ACCESS DOOR 889247-1 (02106)		EA	1	*	*	*	*	*	*	5	7 7		
M F		PIN: HINGE MTG MS20253P5-6600 (96906) MANUFACTURE FROM: ROD, 5 FT 6 IN. REQUIRED, FSN 5315-110-5582		EA	1								7 8		
P F	5340-022-3161	SPRING, HINGE TORSION ZSD14-117-1 (26533)		EA	9	*	*	1	*	*	1	11	7 9		
P F		HINGE, HALF, DOOR 889212-3 (02106)		EA	1	*	*	*	*	*	*	5	7 10		
P F		HINGE, HALF WALL 889211-1 (02106)		EA	1	*	*	*	*	*	*	5	7 11		
M F		CLOSEOUT: DOOR 890338-41 (02106) MANUFACTURE FROM: SHEET, .12 IN. BY 2 1/10 IN. BY 24 1/2 IN. REQUIRED FOR EA CLOSEOUT, P/N MILP3155 (81349)		EA	2								7 12		
M F		CLOSEOUT: DOOR 890338-39 (02106) MANUFACTURE FROM: SHEET, .12 IN. BY 2 1/10 IN. BY 6 FT 1/2 IN. REQUIRED FOR EA CLOSEOUT, P/N MILP3155 (81349)		EA	2								7 13		
O		SCREW: ANTIBACK DRAFT ASSEMBLY MOUNTING MS35224-63 (96906) (USE WITH DOOR ASSEMBLY, P/N 890338-1 (02106), ONLY)		EA	10								7 14		
X2F		VALVE ASSEMBLY, ANTIBACK DRAFT 697281-1 (02106) (USE WITH DOOR ASSEMBLY, P/N 890338-1 (02106), ONLY)		EA	1								7 15		
P F	5315-839-2325	PIN, COTTER: HINGE PIN, 5/32 IN. DIA, 3/4 IN. LG MS24665-132 (96906)		EA	2	1	1	2	1	1	2	24	7 16		

(1) SMR CODE	(2) FEDERAL STOCK NUMBER	(3) DESCRIPTION REF NUMBER & MFR CODE	(4) USABLE ON CODE	(5) QTY INC IN UNIT	(6) 30-DAY DS MAINT ALLOWANCE			(7) 30-DAY GS MAINT ALLOWANCE			(8) 1-YR ALW PER 100 EQUIP CNTGY	(9) ILLUS- TRATION	
					(a)	(b)	(c)	(a)	(b)	(c)		(a)	(b)
					1-20	21-50	51-100	1-20	21-50	51-100		FIG. NO.	ITEM NO.
P F	5315-812-3775	PIN, STRAIGHT, HEADED: HINGE PIN MS20392-1C25 (96906)	EA	2	1	1	2	1	1	2	24	7	17
P F	5310-167-0816	WASHER: HINGE PIN AN960-6 (88044)	EA	4	1	1	2	1	1	2	24	7	18
XI		DAMPER ASSEMBLY, ANTIBACK DRAFT 697283-1 (02106)	EA	1									
M F		PLATE 697283-11 (02106) MANUFACTURE FROM: SHEET, .080 IN. BY 6 3/4 IN. BY 6 3/4 IN. REQUIRED, P/N QQA250-11 (81348)	EA	1								7	19
P F	5320-117-6951	RIVET: HINGE, 1/8 IN. DIA, 3/8 IN. LG MS20426AD4-6 (96906)	EA	8	1	1	2	1	1	2	24	7	20
P F	5340-022-3169	HINGE, DAMPER, RIGHT HAND 697283-13 (02106)	EA	1	*	*	*	*	*	*	5	7	21
P F	5340-022-3172	HINGE, DAMPER, LEFT HAND 697283-15 (02106)	EA	1	*	*	*	*	*	*	5	7	22
P F	5310-685-2651	NUT, PLAIN, HEXAGON: COUNTERWEIGHT, 1/4-28 THD SIZE MS25082-4 (96906)	EA	2	1	1	2	1	1	2	24	7	23
P F	5305-719-5121	SCREW, MACHINE: COUNTERWEIGHT MTG, 1/4-28 THD SIZE, 1 1/2 IN. LG MS51960-86 (96906)	EA	1	1	1	2	1	1	2	24	7	24
P F		GRILL ASSEMBLY, ANTIBACK DRAFT 697285-1 (02106)	EA	1	*	*	*	*	*	*	5	7	25
M F		PLATE 697285-11 (02106) MANUFACTURE FROM: SHEET, .080 IN. BY 7 IN. BY 8 IN. REQUIRED, P/N QQA250-11 (81348)	EA	1								7	26
XI		HOUSING ASSEMBLY 697282-1 (02106)	EA	1								7	27
M F		GASKET, ANTIBACK DRAFT VALVE 697282-25 (02106) MANUFACTURE FROM: SPONGE RUBBER, 1/16 IN. BY 1/2 IN. BY 7 IN. REQUIRED FOR EA GASKET, P/N AMS3195 (81348)	EA	4								7	28
M F		GASKET, ANTIBACK DRAFT VALVE 697282-29 (02106) MANUFACTURE FROM: RUBBER SHEET, .063 IN. BY 1 IN. BY 11 IN. REQUIRED FOR EA GASKET, P/N AMS3302 (81348)	EA	2								7	29
M F		GASKET, DAMPER 697282-27 (02106) MANUFACTURE FROM: RUBBER SHEET, .063 IN. BY 1 IN. BY 11 3/4 IN. REQUIRED FOR EA GASKET, P/N AMS3302 (81348)	EA	2								7	30
P F		HINGE, DAMPER 697282-23 (02106)	EA	2	*	*	*	*	*	*	5	7	31

(1) SMR CODE	(2) FEDERAL STOCK NUMBER	(3) DESCRIPTION	(4) USABLE ON CODE	(5) QTY INC IN UNIT	(6) 30-DAY DS MAINT ALLOWANCE			(7) 30-DAY GS MAINT ALLOWANCE			(8) 1-YR ALW PER 100 EQUIP CNTGY	(9) ILLUS- TRATION	
					(a)	(b)	(c)	(a)	(b)	(c)		(a) FIG. NO.	(b) ITEM NO.
					1-20	21-50	51-100	1-20	21-50	51-100			
P F	5320-932-1972	RIVET: WINDOW FRAME AND STRIP MOUNTING MILR24243-6A402H (81349)	EA	122	REF	REF	REF	REF	REF	REF	REF	7	32
M F		STRIP 890338-27 (02106) MANUFACTURE FROM: SHEET, .063 IN. BY 1/2 IN. BY 24 IN. REQUIRED, P/N QQA250-11 (81348)	EA	1								7	33
M F		SEAL: DOOR 890338-29 (02106) MANUFACTURE FROM: SEAL, 97 IN. REQUIRED FOR EA SEAL, FSN 5330-105-6886	EA	2								7	34
P O	5305-957-7811	SCREW: DOOR STOP MTG MS24693S-272 (96906)	EA	3	REF	REF	REF	REF	REF	REF	REF	7	35
P O	5340-780-7183	DOOR STOP	EA	1	REF	REF	REF	REF	REF	REF	REF	7	36
P F	5320-490-2238	RIVET: DOUBLER MTG MILR24243-6A503H (81349)	EA	8	REF	REF	REF	REF	REF	REF	REF	7	37
M F		DOUBLER: DOOR 890338-31 (02106) MANUFACTURE FROM: SHEET, .090 IN. BY 2 3/4 IN. BY 6 1/2 IN. REQUIRED, P/N QQA200-8 (81348)	EA	1								7	38
P O	5305-043-2682	SCREW: STRIKER MTG MS24694S98 (96906) (USE WITH DOOR ASSEMBLY, P/N 890338-1 (02106), ONLY)	EA	3	1	1	2	1	1	2	24	7	39
M F		STRIKER 890338-19 (02106) MANUFACTURE FROM: ANGLE, .25 IN. BY 1 3/4 IN. BY 1 3/4 IN. BY 2 1/2 IN. REQUIRED, P/N M1020 (81348) (USE WITH DOOR ASSEMBLY, P/N 890338-1 (02106), ONLY)	EA	1								7	40
M F		CLOSEOUT 890338-35 (02106) MANUFACTURE FROM: SHEET, .12 IN. BY 2 1/4 IN. BY 8 1/2 IN. REQUIRED FOR EA CLOSEOUT, P/N MILP3155 (81349) (USE WITH DOOR ASSEMBLY, P/N 890338-1 (02106), ONLY)	EA	2								7	41
M F		CLOSEOUT 890338-37 (02106) MANUFACTURE FROM: SHEET, .12 IN. BY 2 1/4 IN. BY 11 IN. REQUIRED FOR EA CLOSEOUT, P/N MILP3155 (81349) (USE WITH DOOR ASSEMBLY, P/N 890338-1 (02106), ONLY)	EA	2								7	42
M F		CURTAIN ASSEMBLY, BLACKOUT 889280-1 (02106) MANUFACTURE FROM: CLOTH, 14 IN. BY 20 IN. REQUIRED, FSN 8305-290-6036 PILE TAPE, 7 1/2 IN. REQUIRED, FSN 8315-926-4930	EA	1								7	43

(1) SMR CODE	(2) FEDERAL STOCK NUMBER	(3) DESCRIPTION USABLE ON CODE REF NUMBER & MFR CODE	(4) UNIT OF MEAS	(5) QTY INC IN UNIT	(6) 30-DAY DS MAINT ALLOWANCE			(7) 30-DAY GS MAINT ALLOWANCE			(8) 1-YR ALW PER 100 EQUIP CNTGY	(9) ILLUS- TRATION	
					(a)	(b)	(c)	(a)	(b)	(c)		(a)	(b)
					1-20	21-50	51-100	1-20	21-50	51-100		FIG. NO.	ITEM NO.
M F		HOOK TAPE, 60 IN. REQUIRED, FSN 8315-935-6721 THREAD, AS REQUIRED, FSN 8310-988-1300 PILE TAPE; WINDOW 890338-43 (02106) MANUFACTURE FROM: PILE TAPE, 17 IN. REQUIRED FOR EA STRIP, FSN 8315-926-4930	EA	2								7	44
M F		PILE TAPE; WINDOW 890338-45 (02106) MANUFACTURE FROM: PILE TAPE, 14 IN. REQUIRED FOR EA STRIP, FSN 8315-926-4930	EA	2								7	45
P F		FRAME, WINDOW 889253-1 (02106)	EA	8	*	*	*	*	*	*	5	7	46
P F	9330-234-6452	WINDOW 890338-23 (02106)	EA	2	*	*	1	*	*	1	11	7	47
M F		SPACER 890338-21 (02106) MANUFACTURE FROM:	EA	4								7	48
M F		SHEET, 1 IN. BY 12 IN. REQUIRED FOR EA SPACER, FSN 9330-180-9641	EA	4								7	49
M F		STRIP, .12 IN. BY 2 1/4 IN. BY 13 IN. REQUIRED FOR EA CLOSEOUT, MILP3155 (81349)	EA	1								7	50
P F	5305-068-0505	SCREW: GUIDE MTG MS90726-5 (96906) (USE WITH DOOR ASSEMBLY, P/N 890338-3 (02106), ONLY)	EA	4	1	1	2	1	1	2	24	7	51
P F	5310-194-0637	WASHER: GUIDE MTG MS9320-10 (96906) (USE WITH DOOR ASSEMBLY, P/N 890338-3 (02106), ONLY)	EA	8	1	1	2	1	1	2	24	7	52
M F		GUIDE 890338-15 (02106) MANUFACTURE FROM: SHEET, .125 IN. BY 1 IN. BY 3 IN. REQUIRED FOR EA GUIDE, P/N QQA250-11 (81348) (USE WITH DOOR ASSEMBLY, P/N 890338-3 (02106), ONLY)	EA	2								7	53

(1) SMR CODE	(2) FEDERAL STOCK NUMBER	(3) DESCRIPTION REF NUMBER & MFR CODE	(4) USABLE ON CODE	(5) UNIT OF MEAS	QTY INC IN UNIT	(6) 30-DAY DS MAINT ALLOWANCE			(7) 30-DAY GS MAINT ALLOWANCE			(8) 1-YR ALW PER 100 EQUIP CNTGY	(9) ILLUS- TRATION	
						(a)	(b)	(c)	(a)	(b)	(c)		(a)	(b)
						1-20	21-50	51-100	1-20	21-50	51-100		FIG. NO.	ITEM NO.
M F		RISER 890338-17 (02106) MANUFACTURE FROM: SHEET, .19 IN. BY 1 IN. BY 2 1/2 IN. REQUIRED FOR EA RISER, P/N QQA250-11 (81348) (USE WITH DOOR ASSEMBLY, P/N 890338-3 (02106), ONLY)	EA	2									7	54
O		SCREW: LOCK ASSEMBLY MTG AN3-4A (88044) (USE WITH DOOR ASSEMBLY, P/N 890338-3 (02106), ONLY)	EA	4									7	55
P O	5310-188-3744	WASHER: LOCK ASSEMBLY MTG MS9320-09 (96906) (USE WITH DOOR ASSEMBLY, P/N 890338-3 (02106), ONLY)	EA	4	1	1	2	1	1	2	24		7	56
P O	5305-267-8977	SCREW: LOCK ASSEMBLY MTG MS90726-10 (96906) (USE WITH DOOR ASSEMBLY, P/N 890338-3 (02106), ONLY)	EA	4	1	1	2	1	1	2	24		7	57
P O	5310-194-0637	WASHER: LOCK MTG MS9320-10 (96906) (USE WITH DOOR ASSEMBLY, P/N 890338-3 (02106), ONLY)	EA	8	REF	REF	REF	REF	REF	REF	REF		7	58
P O		LOCK ASSEMBLY, MODIFIED ZSD18-180-401 (26533) (USE WITH DOOR ASSEMBLY, P/N 890338-3 (02106), ONLY)	EA	1	*	1	1	*	1	1	16		7	59
P O	5315-839-2325	PIN, COTTER MS24665-132 (96906) (USE WITH DOOR ASSEMBLY, P/N 890338-3 (02106), ONLY)	EA	2	1	1	2	1	1	2	24		7	60
P F	5340-042-8682	NUT, BLIND ASSEMBLY: GUIDE MTG BN528-428-1-24 (73197) (USE WITH DOOR ASSEMBLY, P/N 890338-3 (02106), ONLY)	EA	8	*	1	1	*	1	1	12		7	61
P F	5340-042-8682	NUT, BLIND ASSEMBLY: STRIKER MOUNTING BN528-428-1-24 (73197) (USE WITH DOOR ASSEMBLY, P/N 890338-1 (02106), ONLY)	EA	3	REF	REF	REF	REF	REF	REF	REF		7	61
P F		RIVNUT: DOOR STOP MTG A10B190 (25472)	EA	3	REF	REF	REF	REF	REF	REF	REF		7	62
P F		INSERT: LOCK ASSEMBLY MTG ZSD03-102-3 (26533) (USE WITH DOOR ASSEMBLY, P/N 890338-3 (02106), ONLY)	EA	4	1	1	2	1	1	2	24		7	63
P F	5320-778-3352	NUT, BLIND ASSEMBLY: ANTIBACK DRAFT ASSEMBLY MTG BN360-1032-1 (73197) (USE WITH DOOR ASSEMBLY, P/N 890338-1 (02106), ONLY)	EA	10	*	1	1	*	1	1	12		7	64
F		SCREW: RING AND PLATE ASSEMBLY MOUNTING NAS1105-3 (80205)	EA	40									8	1
P F	5310-167-0820	WASHER: RING AND PLATE ASSEMBLY MOUNTING AN960-516 (88044)	EA	40	1	1	2	1	1	2	24		8	2
P F	5410-522-2482	RING AND PLATE ASSEMBLY V1582 (10424)	EA	4	1	1	2	1	1	2	24		8	3

(1) SMR CODE	(2) FEDERAL STOCK NUMBER	(3) DESCRIPTION USABLE ON CODE	(4) UNIT OF MEAS	(5) QTY INC IN UNIT	(6) 30-DAY DS MAINT ALLOWANCE			(7) 30-DAY GS MAINT ALLOWANCE			(8) 1-YR ALW PER 100 EQUIP CNTGY	(9) ILLUS- TRATION	
					(a)	(b)	(c)	(a)	(b)	(c)		(a)	(b)
					1-20	21-50	51-100	1-20	21-50	51-100		FIG. NO.	ITEM NO.
M F		PLATE FILLER 890331-35 (02106) MANUFACTURE FROM: SHEET, .125 IN. BY 1 3/4 IN. BY 4 IN. REQUIRED FOR EA PLATE, P/N QQA250-11 (81348)	EA	4								8	4
M F		PLATE FILLER 890331-33 (02106) MANUFACTURE FROM: SHEET, .125 IN. BY 3 3/8 IN. BY 5 1/8 IN. REQUIRED FOR EA PLATE, P/N QQA250-11 (81348)	EA	2								8	5
X2F		PANEL ASSEMBLY, ROOF FIXED 890332-1 (02106)	EA	1								8	6
P F	5320-420-2165	RIVET: EXTRUSION AND HINGE MTG MILR24243-7A604H (81349)	EA	177	REF	REF	REF	REF	REF	REF	REF	8	7
P F	5305-781-5690	SCREW: HINGE MTG MS24693S94 (96906)	EA	14	REF	REF	REF	REF	REF	REF	REF	8	8
P F	5340-236-8352	HINGE, HALF 890356-1 (02106)	EA	1	*	1	2	*	1	2	20	8	9
M F		PHENOLIC 890332-23 (02106) MANUFACTURE FROM: PHENOLIC, .010 IN. BY 1 1/8 IN. BY 12 FT REQUIRED, FSN 9330-180-9640	EA	1								8	10
P F	5320-882-8385	RIVET: EXTRUSION MTG MILR24243-6A606H (81349)	EA	28	REF	REF	REF	REF	REF	REF	REF	8	11
M F		EXTRUSION 890332-25 (02106) MANUFACTURE FROM: EXTRUSION, 12 FT REQUIRED, P/N ZSD01-101 (26533)	EA	1								8	12
M F		BAR 890332-13 (02106) MANUFACTURE FROM: BAR, .18 IN. BY 1 IN. BY 11 FT 3 IN., P/N QQA200-18 (81348)	EA	1								8	13
M F		CHANNEL 890332-27 (02106) MANUFACTURE FROM: CHANNEL, .125 IN. BY 1 IN. BY 1 1/2 IN. REQUIRED FOR EA CHANNEL, P/N QQA250-11 (81349)	EA	4								8	14
P F	5320-956-7355	RIVET: EXTRUSION MTG MILR24243-6A604H (81349)	EA	37	REF	REF	REF	REF	REF	REF	REF	8	15
M F		PHENOLIC 890332-21 (02106) MANUFACTURE FROM: PHENOLIC, .125 IN. BY 15/16 IN. BY 2 3/16 IN. REQUIRED FOR EA PHENOLIC, FSN 9330-180-9642	EA	2								8	16
M F		EXTRUSION 890332-15 (02106) MANUFACTURE FROM: EXTRUSION, 6 FT 10 IN. REQUIRED, P/N ZSD01-106 (26533)	EA	1								8	17

(1) SMR CODE	(2) FEDERAL STOCK NUMBER	(3) DESCRIPTION USABLE ON CODE	(4) UNIT OF MEAS	(5) QTY INC IN UNIT	(6) 30-DAY DS MAINT ALLOWANCE			(7) 30-DAY GS MAINT ALLOWANCE			(8) 1-YR ALW PER 100 EQUIP CNTGY	(9) ILLUS- TRATION	
					(a)	(b)	(c)	(a)	(b)	(c)		(a) FIG. NO.	(b) ITEM NO.
					1-20	21-50	51-100	1-20	21-50	51-100			
M F		EXTRUSION 890332-19 (02106) MANUFACTURE FROM: EXTRUSION, 12 FT REQUIRED, P/N ZSD01-106 (26533)	EA	1								8	18
M F		EXTRUSION 890332-17 (02106) MANUFACTURE FROM: EXTRUSION, 6 FT 10 IN. REQUIRED, P/N ZSD01-106 (26533)	EA	1								8	19
P F	5305-995-3444	SCREW: CLAMP MTG MS35207-266 (96906)	EA	2	*	1	1	*	1	1	15	8	20
P F	5310-167-0818	WASHER: CLAMP MTG AN960-10 (88044)	EA	2	REF	REF	REF	REF	REF	REF	REF	8	21
P F		WASHER: STRAP MTG AN960-10 (88044)	EA	4	REF	REF	REF	REF	REF	REF	REF	8	21
M F		SPACER: CLAMP MTG ZSD07-132 (26533) MANUFACTURE FROM: TUBING, 1/4 IN. BY 7/32 IN. REQUIRED FOR EA SPACER, P/N ASTMA269 (02106)	EA	2								8	22
M F		CLAMP, DUCT COVER 889284-1 (02106) MANUFACTURE FROM: BAR, .187 IN. BY 2 IN. BY 6 1/2 IN. REQUIRED FOR EA CLAMP, P/N QOS698 (81348)	EA	2								8	23
P F	5320-882-8386	RIVET: HANDLE MTG MILR24243-6A404H (81349)	EA	12	1	1	2	1	1	2	24	8	24
X2F		HANDLE PLATE ASSEMBLY 890335-5 (02106)	EA	2								8	25
P F	5410-022-2664	COVER ASSEMBLY, DUCT PORT 889200-1 (02106)	EA	2	*	*	*	*	*	*	5	8	26
P F	5320-882-8388	RIVET: HINGE MTG MILR24243-6A403H (81349)	EA	4	REF	REF	REF	REF	REF	REF	REF	8	27
P F	5410-221-8903	HINGE, COVER DUCT 889283-1 (02106)	EA	2	*	1	2	*	1	2	20	8	28
X1		COVER 889238-1 (02106)	EA	2								8	29
X1		ANGLE 889238-11 (02106)	EA	2									
F		SCREW: STRAP MTG AN526001032-8 (88044)	EA	2								8	30
P F	5310-045-3296	WASHER: STRAP MTG AN935-10 (88044)	EA	2	1	1	2	1	1	2	24	8	31
P F	5995-804-6728	STRAP MS25083-2888 (96906)	EA	2	*	*	1	*	*	1	11	8	32
P F	5310-957-6533	NUT, BLIND RIVET: STRAP MTG A108116 (03481)	EA	2	*	1	1	*	1	1	12	8	33
P F	5320-117-6949	RIVET: STRIKE MTG MS20426AD4-4 (96906)	EA	16	REF	REF	REF	REF	REF	REF	REF	8	34
P F	5320-117-6949	RIVET: LATCH MTG MS20426AD4-4 (96906)	EA	24	REF	REF	REF	REF	REF	REF	REF	8	34
P F	5340-978-7995	LATCH, STRIKE ASP2-210-3 (26533)	EA	8	*	*	*	*	*	*	5	8	35

(1) SMR CODE	(2) FEDERAL STOCK NUMBER	(3) DESCRIPTION USABLE ON CODE REF NUMBER & MFR CODE	(4) UNIT OF MEAS	(5) QTY INC IN UNIT	(6) 30-DAY DS MAINT ALLOWANCE			(7) 30-DAY GS MAINT ALLOWANCE			(8) 1-YR ALW PER 100 EQUIP CNTGY	(9) ILLUS- TRATION		
					(a)	(b)	(c)	(a)	(b)	(c)		(a)	(b)	
					1-20	21-50	51-100	1-20	21-50	51-100		FIG. NO.	ITEM NO.	
M F		SEAL 889200-11 (02106) MANUFACTURE FROM: NEOPRENE, .06 IN. BY 1/2 IN. BY 5 FT 2 IN. REQUIRED FOR EA SEAL, P/N MILS6855 (81349)	EA	2								8	36	
P F	5410-018-7464	FLANGE ASSEMBLY, AIR DUCT 889199-1 (02106)	EA	2	*	*	*	*	*	*		5	8	37
M F		SEAL 889199-11 (02106) MANUFACTURE FROM: NEOPRENE, .06 IN. BY 1/2 IN. BY 4 FT 9 IN. REQUIRED, P/N MILS6855 (81349)	EA	1									8	38
P F	5340-992-8141	LATCH STRIKE ZSP2-210-1 (26533)	EA	8	1	1	2	1	1	2	24	8	8	39
P F		INSERT ZSD03-169-1 (26533)	EA	22	REF	REF	REF	REF	REF	REF	REF	REF	8	40
P F	5310-194-8023	RIVNUT: CLAMP MTG A106130 (03481)	EA	2	1	1	2	1	1	2	24	8	8	41
P F	5320-882-8388	RIVET: BRACKET ASSEMBLY MTG MILR24243-6A403H (81349)	EA	74	REF	REF	REF	REF	REF	REF	REF	REF	9	1
M F		BRACKET ASSEMBLY 891782-2 (02106) MANUFACTURE FROM: SHEET, .063 IN. BY 1/2 IN. BY 15 1/2 IN. REQUIRED, P/N QQA250-11 (81348) SHEET, .080 IN. BY 1 3/8 IN. BY 16 IN. REQUIRED, P/N QQA250-11 (81348) RIVET, 1 EA REQUIRED, FSN 5320-117-6826	EA	1									9	2
M F		BRACKET ASSEMBLY 891782-1 (02106) MANUFACTURE FROM: SHEET, .063 IN. BY 1/2 IN. BY 15 1/2 IN. REQUIRED, P/N QQA250-11 (81348) SHEET, .080 IN. BY 1 3/8 IN. BY 16 IN. REQUIRED, P/N QQA250-11 (81348) RIVET, 1 EA REQUIRED, FSN 5320-117-6826	EA	1									9	3
M F		BRACKET ASSEMBLY 891782 (02106) MANUFACTURE FROM: SHEET, .063 IN. BY 1/2 IN. BY 6 1/2 IN. REQUIRED, P/N QQA250-11 (81348) SHEET, .080 IN. BY 1 3/8 IN. BY 7 IN. REQUIRED, P/N QQA250-11 (81348) RIVET, 1 EA REQUIRED, FSN 5320-117-6826	EA	1									9	4
P F	5320-882-8386	RIVET: BRACKET ASSEMBLY MTG MILR24243-6A404H (81349)	EA	10	REF	REF	REF	REF	REF	REF	REF	REF	9	5

(1) SMR CODE	(2) FEDERAL STOCK NUMBER	(3) DESCRIPTION USABLE ON CODE REF NUMBER & MFR CODE	(4) UNIT OF MEAS	(5) QTY INC IN UNIT	(6) 30-DAY DS MAINT ALLOWANCE			(7) 30-DAY GS MAINT ALLOWANCE			(8) 1-YR ALW PER 100 EQUIP CNTGY	(9) ILLUS- TRATION	
					(a)	(b)	(c)	(a)	(b)	(c)		(a) FIG. NO.	(b) ITEM NO.
					1-20	21-50	51-100	1-20	21-50	51-100			
M F		BRACKET ASSEMBLY 891782-4 (02106) MANUFACTURE FROM: SHEET, .063 IN. BY 1/2 IN. BY 6 1/2 IN. REQUIRED, P/N QQA250-11 (81348) SHEET, .080 IN. BY 1 3/8 IN. BY 7 IN. REQUIRED, P/N QQA250-11 (81348) RIVET, 1 EA REQUIRED, FSN 5320-117-6826	EA	1								9	6
F		FASTENER, SNAP MS27940-13N (96906)	EA	17								9	7
F		NUT, BLIND RIVET NAS1329A08875 (80205)	EA	17								9	8
M F		BRACKET ASSEMBLY 891782-5 (02106) MANUFACTURE FROM: SHEET, .063 IN. BY 1/2 IN. BY 3 IN. REQUIRED FOR EA BRACKET ASSEMBLY, P/N QQA250-11 (81348) SHEET, .080 IN. BY 1 3/8 IN. BY 3 1/2 IN. REQUIRED FOR EA BRACKET ASSEMBLY, P/N QQA250-11 (81348) RIVET, 1 EA REQUIRED FOR EA BRACKET ASSEMBLY, FSN 5320-117-6826	EA	5								9	9
M F		BRACKET ASSEMBLY 891782-6 (02106) MANUFACTURE FROM: SHEET, .063 IN. BY 1/2 IN. BY 3 IN. REQUIRED FOR EA BRACKET ASSEMBLY, P/N QQA250-11 (81348) SHEET, .080 IN. BY 1 3/8 IN. BY 3 1/2 IN. REQUIRED FOR EA BRACKET ASSEMBLY, P/N QQA250-11 (81348) RIVET, 1 EA REQUIRED FOR EA BRACKET ASSEMBLY, FSN 5320-117-6826	EA	5								9	10
P F		CAP ASSEMBLY, DRIP 891783-1 (02106)	EA	3	*	*	*	*	*	*	5	10	1
P F	5310-595-5427	WASHER: DRIP CAP, PLATE MTG AN960-416 (88044)	EA	22	REF	REF	REF	REF	REF	REF	REF	10	2
P F	5306-515-8064	BOLT: DRIP CAP MTG AN4-7A (88044)	EA	9	1	1	2	1	1	2	24	10	3
P O	5305-269-3235	SCREW: JACK ASSEMBLY MTG MS90727-59 (96906)	EA	22	1	2	4	1	2	4	48	10	4
P F	5310-595-5427	WASHER, FLAT: TIE DOWN MTG AN960-416 (88044)	EA	8	REF	REF	REF	REF	REF	REF	REF	10	5
P O	5310-167-0821	WASHER: JACK ASSEMBLY MTG AN960-416 (88044)	EA	16	1	2	4	1	2	4	48	10	5
X20		CONTROL ASSEMBLY, CIRCUIT BREAKER RESET 13217E6815 (60532)	EA	1								10	5
X20		CORE: END FITTING RESET CONTROL ROD 13217E6817 (60532)	EA	1								10	6
P O		JACK ASSEMBLY, MAIN LIFTING 889220-1 (02106)	EA	4								10	6
X20		KNOB: CIRCUIT BREAKER RESET CONTROL ROD 13217E6816 (60532)	EA	1								10	7

(1) SMR CODE	(2) FEDERAL STOCK NUMBER	(3) DESCRIPTION REF NUMBER & MFR CODE	(4) USABLE ON CODE	(5) UNIT OF MEAS	(6) 30-DAY DS MAINT ALLOWANCE	(7) 30-DAY GS MAINT ALLOWANCE			(8) 1-YR ALW PER 100 EQUIP CNTGY	(9) ILLUS- TRATION				
						(a)	(b)	(c)		(a)	(b)	(c)	(a)	(b)
O		SCREW: AIR LOCK ADAPTER MTG MS35234-84 (96906)		EA	9						10	7		
O		NUT: AIR LOCK ADAPTER MTG AN354C416 (88044)		EA	9						10	8		
X20		CONTROL ASSEMBLY: PUSH PULL CIRCUIT BREAKER RESET 13217E6815-1 (60532)		EA	1						10	8		
P O		CLAMP, AIR LOCK ADAPTER 891780-1 (02106)		EA	9	1	1	2	1	1	2	24	10	9
P O	5310-181-6033	SPACER: CLAMP S8157C127-100 (79144)		EA	9	*	*	1	*	*	1	11	10	10
P F	5320-882-8385	RIVET: FILLER PLATE MTG MILR24243-6A606H (81349)		EA	16	REF	REF	REF	REF	REF	REF	REF	10	11
M F		PLATE, FILLER 890331-13 (02106) MANUFACTURE FROM: SHEET, .187 IN. BY 2 1/2 IN. BY 3 FT 5 IN. REQUIRED FOR EA PLATE, P/N QQA250-11 (81348)		EA	2								10	12
F		SCREW: TENSION GUIDE MTG NAS1102-5-12 (80205)		EA	6								10	13
F		SCREW: PLATE MTG NAS1102-5-12 (80205)		EA	4								10	13
P F	5310-167-0820	WASHER: TENSION GUIDE MTG AN960-516 (88044)		EA	24	REF	REF	REF	REF	REF	REF	REF	10	14
P F	5306-838-7487	SCREW: PLATE MTG NAS1105-4 (80205)		EA	24	1	1	2	1	1	2	24	10	15
P F		PLATE ASSEMBLY, TENSION CABLE GUIDE 890349-2 (02106)		EA	2	*	*	*	*	*	*	5	10	16
M F		DOUBLER 890331-11 (02106) MANUFACTURE FROM: SHEET, .125 IN. BY 5 1/2 IN. BY 5 1/2 IN. REQUIRED FOR EA DOUBLER, P/N QQA250-11 (81348)		EA	4								10	17
P F		PLATE ASSEMBLY, TENSION CABLE GUIDE 890349-1 (02106)		EA	2	*	*	*	*	*	*	5	10	18
P F	5320-956-7355	RIVET: THRESHOLD MTG MILR24243-6A604H (81349)		EA	17	REF	REF	REF	REF	REF	REF	REF	10	19
P F	5320-956-7355	RIVET: EXTRUSION MTG MILR24243-6A604H (81349)		EA	27	REF	REF	REF	REF	REF	REF	REF	10	19
P F		THRESHOLD 890362-1 (02106)		EA	3	*	*	*	*	*	*	*	10	20
X2F		PANEL END ASSEMBLY 890334-1 (02106)		EA	1								10	21
X2F		PANEL HEADER ASSEMBLY 890345-1 (02106)		EA	1								10	22
F		BOLT: PLATE MTG NAS1105-5-6 (80205)		EA	4								10	23
P F		RIVET: FILLER PLATE MTG MS20426A6-9 (96906)		EA	4	1	1	2	1	1	2	24	10	24
M F		PLATE 890345-22 (02106) MANUFACTURE FROM: SHEET, .187 IN. BY 6 IN. BY 8 IN. REQUIRED, P/N QQA250-11 (81348)		EA	1								10	25
M F		PLATE 890345-21 (02106) MANUFACTURE FROM: SHEET, .187 IN. BY 6 IN. BY 8 IN. REQUIRED, P/N QQA250-11 (81348)		EA	1								10	26
P F	5320-420-2165	RIVET: EXTRUSION MTG MILR24243-6A604H (81349)		EA	16	REF	REF	REF	REF	REF	REF	REF	10	27

(1) SMR CODE	(2) FEDERAL STOCK NUMBER	(3) DESCRIPTION REF NUMBER & MFR CODE	(4) USABLE ON CODE	(5) QTY INC IN UNIT	(6) 30-DAY DS MAINT ALLOWANCE			(7) 30-DAY GS MAINT ALLOWANCE			(8) 1-YR ALW PER 100 EQUIP CNTGY	(9) ILLUS- TRATION	
					(a)	(b)	(c)	(a)	(b)	(c)		(a)	(b)
					1-20	21-50	51-100	1-20	21-50	51-100		FIG. NO.	ITEM NO.
M F		PLATE FILLER 890345-19 (02106) MANUFACTURE FROM: SHEET, .187 IN. BY 2 IN. BY 3 FT 6 IN. REQUIRED, P/N QQA250-11 (81348)	EA	1							10	28	
M F		CLOSEOUT EXTRUSION 890345-13 (02106) MANUFACTURE FROM: EXTRUSION, 4 FT 2 IN. REQUIRED, P/N ZSD01-101 (26533)	EA	1							10	29	
M F		PLATE FILLER 890345-23 (02106) MANUFACTURE FROM: SHEET, .125 IN. BY 2 IN. BY 3 IN. REQUIRED FOR EA PLATE, P/N QQA250-11 (81348)	EA	2							10	30	
M F		CLOSEOUT PHENOLIC 890345-17 (02106) MANUFACTURE FROM: SHEET, 6 IN. REQUIRED FOR EA CLOSEOUT, FSN 9330-180-9642	EA	2							10	31	
M F		CLOSEOUT PHENOLIC 890345-15 (02106) MANUFACTURE FROM: SHEET, 4 FT 2 IN. REQUIRED, FSN 9330-180-9642	EA	1							10	32	
F		RIVET: EXTRUSION MTG MILR24243-7A606H (81349)	EA	47							10	33	
M F		CLOSEOUT PHENOLIC 890334-25 (02106) MANUFACTURE FROM: SHEET, 2 IN. REQUIRED, FSN 9330-180-9642	EA	1									
M F		EXTRUSION CLOSEOUT 890334-19 (02106) MANUFACTURE FROM: EXTRUSION, 6 FT 4 IN. REQUIRED, P/N ZSD01-101 (26533)	EA	1							10	34	
M F		CLOSEOUT PHENOLIC 890334-23 (02106) MANUFACTURE FROM: SHEET, 3 IN. REQUIRED FOR EA CLOSEOUT, FSN 9330-180-9642	EA	3							10	35	
M F		EXTRUSION CLOSEOUT 890334-17 (02106) MANUFACTURE FROM: EXTRUSION, 6 FT 3 IN. REQUIRED, P/N ZSD01-106 (26533)	EA	1							10	36	
M F		PLATE FILLER 890334-31 (02106) MANUFACTURE FROM: SHEET, .080 IN. BY 2 IN. BY 5 FT 5 IN. REQUIRED FOR EA PLATE, P/N QQA250-11 (81348)	EA	2							10	37	

(1) SMR CODE	(2) FEDERAL STOCK NUMBER	(3) DESCRIPTION REF NUMBER & MFR CODE	(4) USABLE ON CODE	(5) QTY INC IN UNIT	(6) 30-DAY DS MAINT ALLOWANCE			(7) 30-DAY GS MAINT ALLOWANCE			(8) 1-YR ALW PER 100 EQUIP CNTGY	(9) ILLUS- TRATION	
					(a)	(b)	(c)	(a)	(b)	(c)		(a)	(b)
					1-20	21-50	51-100	1-20	21-50	51-100		FIG. NO.	ITEM NO.
M F		EXTRUSION CLOSEOUT 890334-20 (02106) MANUFACTURE FROM: EXTRUSION, 6 FT 4 IN. REQUIRED, P/N ZSD01-101 (26533)	EA	1								10	38
M F		EXTRUSION CLOSEOUT 890334-21 (02106) MANUFACTURE FROM: EXTRUSION, 6 FT 9 IN. REQUIRED, P/N ZSD01-101 (26533)	EA	1								10	39
F		SCREW: TIE DOWN MTG MS35308-307 (96906)	EA	8								10	40
P F	1670-885-0855	TIE DOWN CARGO SP2158-3 (96603)	EA	2	*	1	1	*	1	1	14	10	41
X2F		CAN, DEEP DRAWN ZR31-25 (26533)	EA	2									
X2F		BOX ASSEMBLY ZSD16-181-1 (26533)	EA	1								10	42
P F	5310-917-6086	NUT SS10KB80 (03481)	EA	2	1	1	2	1	1	2	24	10	43
P F		INSERT: STOWAGE ASSEMBLY AND JACK ASSEMBLY MTG ZSD03-192 (26533)	EA	24	1	1	2	1	1	2	24	10	44
P F		INSERT: EXTRUSION MTG ZSD03-191 (26533)	EA	14	REF	REF	REF	REF	REF	REF	REF	10	45
P F		INSERT: PLATE ASSEMBLY MTG ZSD03-102-16 (26533)	EA	4	1	1	2	1	1	2	24	10	46
M F		CLOSEOUT PHENOLIC 890334-27 (02106) MANUFACTURE FROM: SHEET, 17 IN. REQUIRED FOR EA CLOSEOUT, FSN 9330-180-9642	EA	2								10	47
M F		CLOSEOUT PHENOLIC 890334-29 (02106) MANUFACTURE FROM: SHEET, 15 IN. REQUIRED FOR EA CLOSEOUT, FSN 9330-180-9642	EA	2								10	48
P F		INSERT: HEADER MTG ZSD03-169-1 (26533)	EA	9	REF	REF	REF	REF	REF	REF	REF	10	49
P F		INSERT: AIR LOCK ADAPTER MTG ZSD03-102-5 (26533)	EA	6	REF	REF	REF	REF	REF	REF	REF	10	50
P F	5305-068-0507	SCREW: GUIDE MTG MS90726-7 (96906)	EA	6	1	1	2	1	1	2	24	11	1
P F	5310-194-0637	WASHER: GUIDE MTG MS9320-10 (96906)	EA	6	REF	REF	REF	REF	REF	REF	REF	11	2
M F		GUIDE 890338-15 (02106) MANUFACTURE FROM: SHEET, .125 IN. BY 1 IN. BY 3 IN. REQUIRED FOR EA GUIDE, P/N QQA250-11 (81348)	EA	3								11	3

(1) SMR CODE	(2) FEDERAL STOCK NUMBER	(3) DESCRIPTION USABLE ON CODE	(4) UNIT OF MEAS	(5) QTY INC IN UNIT	(6) 30-DAY DS MAINT ALLOWANCE			(7) 30-DAY GS MAINT ALLOWANCE			(8) 1-YR ALW PER 100 EQUIP CNTGY	(9) ILLUS- TRATION	
					(a)	(b)	(c)	(a)	(b)	(c)		(a)	(b)
					1-20	21-50	51-100	1-20	21-50	51-100		FIG. NO.	ITEM NO.
M F		RISER: GUIDE 890338-17 (02106) MANUFACTURE FROM: SHEET, .19 IN. BY 1 IN. BY 2 1/2 IN. REQUIRED FOR EA RISER, P/N QQA250-11 (81348)	EA	6								11	4
P F	5305-068-0514	SCREW: PLATE MTG MS90727-7 (96906)	EA	13	1	1	2	1	1	2	24	11	5
P F	5310-595-5427	WASHER, FLAT: TIE DOWN MTG AN960-416 (88044)	EA	8	REF	REF	REF	REF	REF	REF	REF	11	6
P F		PLATE, ATTACHMENT MOBILIZER 890367-1 (02106)	EA	2	*	*	*	*	*	*	5	11	7
F		SCREW: PLATE MTG NAS1102-08-6 (80205)	EA	16								11	8
P F		PLATE, MOBILIZER ATTACHMENT 890346-1 (02106)	EA	2	*	*	*	*	*	*	5	11	9
P F	5305-043-2682	SCREW: LATCH ASSEMBLY MTG MS24694S98 (96906)	EA	2	REF	REF	REF	REF	REF	REF	REF	11	10
P F	5410-221-8904	LATCH ASSEMBLY VHC250-35S (98003)	EA	4	1	1	2	1	1	2	24	11	11
F		BOLT: BRACKET MTG AN4-5A (88044)	EA	6								11	12
P F	5305-043-2677	SCREW: BRACKET MTG MS24694S94 (96906)	EA	8	1	1	2	1	1	2	24	11	13
F		SCREW: PLATE MTG NAS1102-5-12 (80205)	EA	4								11	13
P F		BRACKET, ATTACHMENT TOW CABLE 890348-1 (02106)	EA	4	*	*	*	*	*	*	5	11	14
O		SCREW: LEVEL ASSEMBLY MTG MS24584-57 (96906)	EA	4								11	15
P O	5310-167-0818	WASHER: LEVEL ASSEMBLY MTG AN960-10 (88044)	EA	4	REF	REF	REF	REF	REF	REF	REF	11	16
P O	5210-134-3248	LEVEL ASSEMBLY 890357-1 (02106)	EA	2	REF	REF	REF	REF	REF	REF	REF	11	17
P O		CUP, END 890357-13 (02106)	EA	2	REF	REF	REF	REF	REF	REF	REF	11	18
P O		VIAL, LEVEL 21-8X35 (32868)	EA	1	REF	REF	REF	REF	REF	REF	REF	11	19
X2F		PANEL END ASSEMBLY 890334-3 (02106)	EA	1								11	20
X2F		PANEL HEADER ASSEMBLY 890345-1 (02106)	EA	1								11	21
F		BOLT: PLATE MTG NAS1105-5-6 (80205)	EA	4								11	22
P F	5320-855-2185	RIVET: FILLER PLATE MTG MS20426A6-9 (96906)	EA	4	REF	REF	REF	REF	REF	REF	REF	11	23
M F		PLATE 890345-22 (02106) MANUFACTURE FROM: SHEET, .187 IN. BY 6 IN. BY 8 IN. REQUIRED, P/N QQA250-11 (81348)	EA	1								11	24

(1) SMR CODE	(2) FEDERAL STOCK NUMBER	(3) DESCRIPTION REF NUMBER & MFR CODE	(4) USABLE ON CODE	(5) UNIT OF MEAS	(6) 30-DAY DS MAINT ALLOWANCE	(7) 30-DAY GS MAINT ALLOWANCE			(8) 1-YR ALW PER 100 EQUIP CNTGY	(9) ILLUS- TRATION				
						(a)	(b)	(c)		(a)	(b)	(c)	(a)	(b)
M F		PLATE 890345-21 (02106) MANUFACTURE FROM: SHEET, .187 IN. BY 6 IN. BY 8 IN. REQUIRED, P/N QQA250-11 (81348)	EA	1							11	25		
P F	5320-420-2165	RIVET: HEADER MTG MILR24243-6A604H (81349)	EA	16	REF	REF	REF	REF	REF	REF	REF	11	26	
M F		PLATE FILLER 890345-19 (02106) MANUFACTURE FROM: SHEET, .187 IN. BY 2 IN. BY 3 FT 6 IN. REQUIRED, P/N QQA250-11 (81348)	EA	1								11	27	
M F		CLOSEOUT EXTRUSION 890345-13 (02106) MANUFACTURE FROM: EXTRUSION, 4 FT 2 IN. REQUIRED, P/N ZSD01-101 (26533)	EA	1								11	28	
M F		PLATE FILLER 890345-23 (02106) MANUFACTURE FROM: SHEET, .125 IN. BY 2 IN. BY 3 IN. REQUIRED FOR EA PLATE, P/N QQA250-11 (81348)	EA	2								11	29	
M F		CLOSEOUT PHENOLIC 890345-17 (02106) MANUFACTURE FROM: SHEET, 6 IN. REQUIRED FOR EA CLOSEOUT, FSN 9330-180-9642	EA	2								11	30	
M F		CLOSEOUT PHENOLIC 890345-15 (02106) MANUFACTURE FROM: SHEET, 4 FT 2 IN. REQUIRED, FSN 9330-180-9642	EA	1								11	31	
F		RIVET: EXTRUSION MTG MILR24243-7A606H (81349)	EA	47								11	32	
M F		EXTRUSION CLOSEOUT 890334-19 (02106) MANUFACTURE FROM: EXTRUSION, 6 FT 4 IN. REQUIRED, P/N ZSD01-101 (26533)	EA	1								11	33	
P F		INSERT: HEADER MTG ZSD03-102-5 (26533)	EA	6	REF	REF	REF	REF	REF	REF	REF	11	34	
M F		CLOSEOUT PHENOLIC 890334-23 (02106) MANUFACTURE FROM: SHEET, 3 IN. REQUIRED FOR EA CLOSEOUT, FSN 9330-180-9642	EA	3								11	35	
P F	5320-956-7355	RIVET: EXTRUSION MTG MILR24243-6A604H (81349)	EA	27	REF	REF	REF	REF	REF	REF	REF	11	36	
M F		CLOSEOUT PHENOLIC 890334-25 (02106) MANUFACTURE FROM: SHEET, 2 IN. REQUIRED, FSN 9330-180-9642	EA	1										

(1) SMR CODE	2) FEDERAL STOCK NUMBER	(3) DESCRIPTION USABLE ON CODE	(4) UNIT OF MEAS	(5) QTY INC IN UNIT	(6) 30-DAY DS MAINT ALLOWANCE			(7) 30-DAY GS MAINT ALLOWANCE			(8) 1-YR ALW PER 100 EQUIP CNTGY	(9) ILLUS- TRATION	
					(a)	(b)	(c)	(a)	(b)	(c)		(a)	(b)
					1-20	21-50	51-100	1-20	21-50	51-100		FIG. NO.	ITEM NO.
M F		EXTRUSION CLOSEOUT 890334-18 (02106) MANUFACTURE FROM: EXTRUSION, 6 FT 3 IN. REQUIRED, P/N ZSD01-106 (26533)	EA	1								11	37
M F		CLOSEOUT PHENOLIC 890334-27 (02106) MANUFACTURE FROM: SHEET, 17 IN. REQUIRED FOR EA CLOSEOUT, FSN 9330-180-9642	EA	2								11	38
M F		PLATE FILLER 890334-31 (02106) MANUFACTURE FROM: SHEET, .080 IN. BY 2 IN. BY 5 FT 5 IN. REQUIRED FOR EA PLATE, P/N QQA250-11 (81348)	EA	2								11	39
M F		EXTRUSION CLOSEOUT 890334-20 (02106) MANUFACTURE FROM: EXTRUSION, 6 FT 4 IN. REQUIRED, P/N ZSD01-101 (26533)	EA	1								11	40
F		SCREW: TIE DOWN MTG MS35308-307 (96906)	EA	8								11	41
P F	1670-885-0855	TIE DOWN CARGO SP2158-3 (96603)	EA	2	REF	REF	REF	REF	REF	REF	REF	11	42
X2F		CAN DEEP DRAWN ZR31-25 (26533)	EA	2								11	43
X2F		BOX ASSEMBLY ZSD16-181-1 (26533)	EA	1								11	44
P F	5310-917-6086	NUT SS10KB80 (03481)	EA	2	REF	REF	REF	REF	REF	REF	REF	11	45
M F		CLOSEOUT PHENOLIC 890334-29 (02106) MANUFACTURE FROM: SHEET, 15 IN. REQUIRED FOR EA CLOSEOUT, FSN 9330-180-9642	EA	2								11	46
M F		EXTRUSION CLOSEOUT 890334-22 (02106) MANUFACTURE FROM: EXTRUSION, 6 FT 9 IN. REQUIRED, P/N ZSD01-101 (26533)	EA	1								11	47
P F		INSERT ZSD03-189-2 (26533)	EA	2	1	1	2	1	1	2	24	11	48
P F		INSERT: GUIDE MTG ZSD03-189-3 (26533)	EA	8	REF	REF	REF	REF	REF	REF	REF	11	49
P F		INSERT: CLOSEOUT MTG ZSD03-102-4 (26533)	EA	28	1	1	2	1	1	2	24	11	50
P F		INSERT: EXTRUSION MTG ZSD03-191 (26533)	EA	14	REF	REF	REF	REF	REF	REF	REF	11	51
P O		SCREW: CLAMP MTG MS35234-84 (96906)	EA	16	REF	REF	REF	REF	REF	REF	REF	12	1
P O	5310-176-8121	NUT: CLAMP MTG AN345416 (88044)	EA	16	REF	REF	REF	REF	REF	REF	REF	12	2
P O		CLAMP, AIR LOCK ADAPTER 891781-1 (02106)	EA	16	REF	REF	REF	REF	REF	REF	REF	12	3

(1) SMR CODE	(2) FEDERAL STOCK NUMBER	(3) DESCRIPTION USABLE ON CODE	(4) UNIT OF MEAS	(5) QTY INC IN UNIT	(6) 30-DAY DS MAINT ALLOWANCE			(7) 30-DAY GS MAINT ALLOWANCE			(8) 1-YR ALW PER 100 EQUIP CNTGY	(9) ILLUS- TRATION	
					(a)	(b)	(c)	(a)	(b)	(c)		(a) FIG. NO.	(b) ITEM NO.
					1-20	21-50	51-100	1-20	21-50	51-100			
P O	5310-529-6513	WASHER: CLAMP MTG S8157C127-156 (79144)	EA	16	REF	REF	REF	REF	REF	REF	REF	12	4
F		RIVET: FILLER PLATE MTG MILR24243-7A606H (81349)	EA	16								12	5
M F		PLATE, FILLER 890331-15 (02106) MANUFACTURE FROM: SHEET, .187 IN. BY 2 1/2 IN. BY 4 FT REQUIRED FOR EA PLATE, P/N QQA250-11 (81348)	EA	2								12	6
O		SCREW: TENSION PLATE AND LEVEL BRACKET MTG NAS1102-5-12 (80205)	EA	24								12	7
P F	5320-855-2185	RIVET: FILLER PLATE MTG MS20426A6-9 (96906)	EA	6	REF	REF	REF	REF	REF	REF	REF	12	8
P F		PLATE, TENSION 890350-2 (02106)	EA	1	*	*	*	*	*	*	*	5	9
P F		PLATE, TENSION 890350-1 (02106)	EA	1	*	*	*	*	*	*	*	5	10
P F	5306-225-9081	SCREW: TENSION PLATE MTG MS90725-36 (96906)	EA	32	1	2	3	1	2	3	36	12	11
P F	5320-882-8385	RIVET: TENSION PLATE MTG MILR24243-6A606H (81349)	EA	32	REF	REF	REF	REF	REF	REF	REF	12	12
P F		PLATE, TENSION 890351-1 (02106)	EA	4	*	*	*	*	*	*	*	5	13
P O	5210-134-3248	LEVEL ASSEMBLY 890357-1 (02106)	EA	1	REF	REF	REF	REF	REF	REF	REF	12	15
P O		CUP, END 890357-13 (02106)	EA	2	REF	REF	REF	REF	REF	REF	REF	12	16
P O		VIAL, LEVEL 21-8X35 (32868)	EA	1	REF	REF	REF	REF	REF	REF	REF	12	17
X2F		PANEL SIDE ASSEMBLY 890333-1 (02106)	EA	1								12	18
X2F		PANEL HEADER ASSEMBLY 890345-1 (02106)	EA	1								12	19
F		BOLT: PLATE MTG NAS1103-5-6 (80205)	EA	4								12	20
F	5310-167-0820	WASHER: STEPS AND PLATE MTG AN960-516 (88044)	EA	8								12	21
M F		PLATE 890345-22 (02106) MANUFACTURE FROM: SHEET, .187 IN. BY 6 IN. BY 8 IN. REQUIRED, P/N QQA250-11 (81348)	EA	1								12	22
M F		PLATE 890345-21 (02106) MANUFACTURE FROM: SHEET, .187 IN. BY 6 IN. BY 8 IN. REQUIRED, P/N QQA250-11 (81348)	EA	1								12	23
P F	5320-420-2165	RIVET: FILLER PLATE MTG MILR24243-7A604H (81349)	EA	16	REF	REF	REF	REF	REF	REF	REF	12	24

(1) SMR CODE	(2) FEDERAL STOCK NUMBER	(3) DESCRIPTION REF NUMBER & MFR CODE	(4) USABLE ON CODE	(5) QTY INC IN UNIT	(6) 30-DAY DS MAINT ALLOWANCE			(7) 30-DAY GS MAINT ALLOWANCE			(8) 1-YR ALW PER 100 EQUIP CNTGY	(9) ILLUS- TRATION	
					(a)	(b)	(c)	(a)	(b)	(c)		(a)	(b)
					1-20	21-50	51-100	1-20	21-50	51-100		FIG. NO.	ITEM NO.
M F		PLATE FILLER 890345-19 (02106) MANUFACTURE FROM: SHEET, .187 IN. BY 2 IN. BY 3 FT 6 IN. REQUIRED, P/N QQA250-11 (81348)	EA	1								12	25
M F		CLOSEOUT EXTRUSION 890345-13 (26533) MANUFACTURE FROM: EXTRUSION, 4 FT 2 IN. REQUIRED, P/N ZSD01-101 (26533)	EA	1								12	26
M F		PLATE FILLER 890345-23 (02106) MANUFACTURE FROM: SHEET, .125 IN. BY 2 IN. BY 3 IN. REQUIRED FOR EA PLATE, P/N QQA250-11 (81348)	EA	2								12	27
M F		CLOSEOUT PHENOLIC 890345-17 (02106) MANUFACTURE FROM: SHEET, 5 1/2 IN. REQUIRED FOR EA CLOSEOUT, FSN 9330-180-9642	EA	2								12	28
M F		CLOSEOUT PHENOLIC 890345-15 (02106) MANUFACTURE FROM: SHEET, 4 FT 2 IN. REQUIRED, FSN 9330-180-9642	EA	1								12	29
M F		PLATE FILLER 890333-21 (02106) MANUFACTURE FROM: SHEET, .187 IN. BY 2 IN. BY 5 FT 7 IN. REQUIRED FOR EA PLATE, P/N QQA250-11 (81348)	EA	1								12	30
M F		CLOSEOUT EXTRUSION 890333-14 (02106) MANUFACTURE FROM: EXTRUSION, 6 FT 1/4 IN. REQUIRED, P/N ZSD01-101 (26533)	EA	1								12	31
M F		CLOSEOUT, PHENOLIC 890333-19 (02106) MANUFACTURE FROM: SHEET, .12 IN. BY 2 1/4 IN. BY 2 1/4 IN. REQUIRED FOR EA CLOSEOUT, P/N MILP3155 (81349)	EA	2								12	32
M F		CLOSEOUT, PHENOLIC 890333-15 (02106) MANUFACTURE FROM: SHEET, .12 IN. BY 2 1/4 IN. BY 3 FT 9 IN. REQUIRED FOR EA CLOSEOUT, P/N MILP3155 (81349)	EA	4								12	33
M F		CLOSEOUT, PHENOLIC 890333-17 (02106) MANUFACTURE FROM: SHEET, .12 IN. BY 2 1/4 IN. BY 6 FT 6 IN. REQUIRED FOR EA CLOSEOUT, P/N MILP3155 (81349)	EA	2								12	34

(1) SMR CODE	(2) FEDERAL STOCK NUMBER	(3) DESCRIPTION REF NUMBER & MFR CODE	(4) USABLE ON CODE	(5) QTY INC IN UNIT	(6) 30-DAY DS MAINT ALLOWANCE			(7) 30-DAY GS MAINT ALLOWANCE			(8) 1-YR ALW PER 100 EQUIP CNTGY	(9) ILLUS- TRATION	
					(a)	(b)	(c)	(a)	(b)	(c)		(a)	(b)
					1-20	21-50	51-100	1-20	21-50	51-100		FIG. NO.	ITEM NO.
M F		CLOSEOUT, EXTRUSION 890333-13 (02106) MANUFACTURE FROM: EXTRUSION, 6 FT 4 IN. REQUIRED, P/N ZSD01-101 (26533)	EA	42									
			EA	1								12	35
X2F		BOX ASSEMBLY ZSD16-181-1 (26533)	EA	1								12	36
P F	5310-917-6086	NUT SS10KB80 (03481)	EA	2	REF	REF	REF	REF	REF	REF	REF	12	37
F		BOLT: STEPS MTG AN5-7A (88044)	EA	8								12	38
P F	6625-568-7798	STEP FOLDING 575709 (19220)	EA	4	*	*	1	*	*	1	11	12	39
P F	5320-462-2320	RIVET: RUBBING STRIP MTG MILR24243-6A502H (81349)	EA	20	1	1	2	1	1	2	24	12	40
P F		STRIP RUBBER ZSD01-113-4 (26533)	EA	2	*	*	*	*	*	*	5	12	41
P F		INSERT: PLATE MTG ZSD03-189-2 (26533)	EA	10	REF	REF	REF	REF	REF	REF	REF	12	42
P F		INSERT: EXTRUSION MTG ZSD03-102-5 (26533)	EA	12	REF	REF	REF	REF	REF	REF	REF	12	43
P F		INSERT: EXTRUSION MTG ZSD03-169-1 (26533)	EA	14	REF	REF	REF	REF	REF	REF	REF	12	44
X2F		PANEL ASSEMBLY, FLOOR FIXED 890341-1 (02106)	EA	1								13	1
P F	5306-225-9089	SCREW: DOUBLER AND SKID MTG MS90726-34 (96906)	EA	64	1	2	4	1	2	4	48	13	2
P F	5310-081-4219	WASHER: DOUBLER AND SKID MTG MS27183-12 (96906)	EA	64	1	2	4	1	2	4	48	13	3
M F		DOUBLER 890341-21 (02106) MANUFACTURE FROM: SHEET, .125 IN. BY 3 IN. BY 11 3/4 IN. REQUIRED FOR EA DOUBLER, P/N QQA250-11 (81348)	EA	4								13	4
P F		BRACKET MOBILIZER 890347-1 (02106) (COMPONENTS SAME AS BRACKET MOBILIZER, P/N 890347-2 (02106))	EA	2	*	*	*	*	*	*	5		
P F		BRACKET MOBILIZER 890347-2 (02106)	EA	2	*	*	*	*	*	*	5		
X1		WELD ASSEMBLY 890342-3 (02106)	EA	1									
X1		PLATE 890342-15 (02106)	EA	1									
P F	5310-732-0846	NUT MS51968-1 (96906)	EA	3	1	1	2	1	1	2	24		
X1		CHANNEL 890347-11 (02106)	EA	1								13	5
P F	5305-225-3839	BOLT: TIE DOWN RING MTG MS90725-8 (96906)	EA	3	1	1	2	1	1	2	24	13	6
P F	5310-194-0637	WASHER: TIE DOWN RING MS9320-10 (96906)	EA	3	REF	REF	REF	REF	REF	REF	REF	13	7

(1) SMR CODE	(2) FEDERAL STOCK NUMBER	(3) DESCRIPTION USABLE ON CODE REF NUMBER & MFR CODE	(4) UNIT OF MEAS	(5) QTY INC IN UNIT	(6) 30-DAY DS MAINT ALLOWANCE			(7) 30-DAY GS MAINT ALLOWANCE			(8) 1-YR ALW PER 100 EQUIP CNTGY	(9) ILLUS- TRATION	
					(a)	(b)	(c)	(a)	(b)	(c)		(a)	(b)
					1-20	21-50	51-100	1-20	21-50	51-100		FIG. NO.	ITEM NO.
P F	5410-299-1182	RING, TIE DOWN SP2804-2 (96603)	EA	1	1	1	2	1	1	2	24	13	8
X1		PIN 890347-13 (02106)	EA	1									
P F	5320-882-8385	RIVET MILR24243-6A606H (81349)	EA	2	REF	REF	REF	REF	REF	REF	REF	13	9
F		NUT, SELF-LOCKING; CLOSEOUT MTG MS20365-1032 (96906)	EA	22								13	10
P F	5310-167-0834	WASHER, LOCK; CLOSEOUT MTG AN960-10L (88044)	EA	22	1	2	4	1	2	4	48	13	11
P F	5310-167-0818	WASHER, FLAT; CLOSEOUT MTG AN960-10 (88044)	EA	22	REF	REF	REF	REF	REF	REF	REF	13	12
F		BOLT; CLOSEOUT MTG NAS1103-7W (80205)	EA	8								13	13
P F	5320-420-2163	RIVET; SKID MTG MILR24243-7A604F (81349)	EA	72	1	2	4	1	2	4	48	13	14
P F		SKID ASSEMBLY 890342-1 (02106)	EA	2	1	1	2	1	1	2	24	13	
P F		SKID EXTRUSION 890342-11 (02106)	EA	1	*	*	*	*	*	*	5	13	15
P F		PLATE 890343-13 (02106)	EA	1	*	*	*	*	*	*	5		
P F		ROLL 890343-15 (02106)	EA	1	*	*	*	*	*	*	5		
P F	5320-952-4159	RIVET; DOUBLER MTG AD64S (07707)	EA	68	1	2	4	1	2	4	48	13	16
M F		DOUBLER FLOOR FORKLIFT 890366-1 (02106) MANUFACTURE FROM: SHEET, .125 IN. BY 10 1/2 IN. BY 6 FT 9 IN. REQUIRED FOR EA DOUBLER, P/N QQA250-11 (81348)	EA	2								13	17
P F	5305-337-3090	SCREW; PLATE MTG AN507-1032-8 (88044)	EA	4	1	1	2	1	1	2	24	13	18
M F		PLATE 891785-11 (02106) MANUFACTURE FROM: SHEET, .188 IN. BY 1 1/4 IN. BY 2 1/4 IN. REQUIRED FOR EA PLATE, P/N QQA250-11 (81348)	EA	2								13	19
P F	5320-117-6953	RIVET; PLATE MTG MS20426AD4-8 (96906)	EA	4	REF	REF	REF	REF	REF	REF	REF	13	20
M F		PLATE 891785-13 (02106) MANUFACTURE FROM: SHEET, .125 IN. BY 1 IN. BY 1 1/4 IN. BY 1 IN. REQUIRED FOR EA PLATE, P/N QQA250-11 (81348)	EA	2								13	21
P F	5320-956-7355	RIVET; EXTRUSION MTG MILR24243-6A604H (81349)	EA	33	REF	REF	REF	REF	REF	REF	REF	13	22
M F		EXTRUSION 890341-25 (02106) MANUFACTURE FROM: EXTRUSION, 12 FT REQUIRED, P/N ZSD01-106 (26533)	EA	1								13	23

(1) SMR CODE	(2) FEDERAL STOCK NUMBER	(3) DESCRIPTION REF NUMBER & MFR CODE	(4) USABLE ON CODE	(5) UNIT OF MEAS	QTY INC IN UNIT	(6) 30-DAY DS MAINT ALLOWANCE			(7) 30-DAY GS MAINT ALLOWANCE			(8) 1-YR ALW PER 100 EQUIP CNTGY	(9) ILLUS- TRATION	
						(a)	(b)	(c)	(a)	(b)	(c)		(a)	(b)
						1-20	21-50	51-100	1-20	21-50	51-100		FIG. NO.	ITEM NO.
M F		EXTRUSION 890341-37 (02106) MANUFACTURE FROM: EXTRUSION, 6 FT 10 IN. REQUIRED, P/N ZSD01-106 (26533)	EA		1								13	24
M F		EXTRUSION 890341-28 (02106) MANUFACTURE FROM: EXTRUSION, 6 FT 10 IN. REQUIRED, P/N ZSD01-106 (26533)	EA		1								13	25
P F	5305-964-9221	SCREW: HINGE MTG MS24693S294 (96906)	EA		14	1	1	2	1	1	2	24	13	26
P F	5320-420-2165	RIVET: HINGE MTG MILR24243-7A604H (81349)	EA		171	REF	REF	REF	REF	REF	REF	REF	13	27
P F	5340-236-8352	HINGE, HALF 890356-1 (02106)	EA		1	*	1	2	*	1	2	20	13	28
P F	5320-486-8251	RIVET: STRIP MTG MILR242437A602H (81349)	EA		39	REF	REF	REF	REF	REF	REF	REF	13	29
M F		STRIP 890331-17 (02106) MANUFACTURE FROM: SHEET, .063 IN. BY 1/2 IN. BY 12 FT REQUIRED, P/N QQA250-11 (81348)	EA		1								13	30
M F		SEAL 890331-19 (02106) MANUFACTURE FROM: SEAL, 12 FT 2 IN. REQUIRED, FSN 5330-105-8667	EA		1								13	31
M F		CLOSEOUT 890341-23 (02106) MANUFACTURE FROM: SHEET, .12 IN. BY 2.5 IN. BY 12 FT REQUIRED, P/N 890341-23 (02106)	EA		1								13	32
P F		TUBE ASSEMBLY 890341-3 (02106)	EA		1	*	*	*	*	*	*	5	13	
P F	5305-957-7814	SCREW MS24693S48 (96906)	EA		6	1	1	2	1	1	2	24	13	33
P F		RING 890341-13 (02106)	EA		1	*	*	*	*	*	*	5	13	34
P F	5340-182-4603	INSERT BN514-332-8 (73197)	EA		6	1	1	2	1	1	2	24	13	35
P F		INSERT: PLATE MTG ZSD03-102-3 (26533)	EA		4	REF	REF	REF	REF	REF	REF	REF	13	36
P F	5340-042-8683	INSERT: BRACKET MTG BN528-524-3-24 (73197)	EA		66	1	2	4	1	2	4	48	13	37
P F		INSERT: EXTRUSION MTG ZSD03-169-1 (26533)	EA		14	1	1	2	1	1	2	24	13	38
P F		PLUG ASSEMBLY 890365-1 (02106)	EA		1	*	*	1	*	*	1	11	13	39
M F		GASKET 890365-17 (02106) MANUFACTURE FROM: RUBBER, .040 IN. BY 6 1/2 IN. BY 6 1/2 IN. REQUIRED, P/N AMS3195 (81343)	EA		1								13	40

(1) SMR CODE	(2) FEDERAL STOCK NUMBER	(3) DESCRIPTION REF NUMBER & MFR CODE	(4) USABLE ON CODE	(5) UNIT OF MEAS	QTY INC IN UNIT	(6) 30-DAY DS MAINT ALLOWANCE			(7) 30-DAY GS MAINT ALLOWANCE			(8) 1-YR ALW PER 100 EQUIP CNTGY	(9) ILLUS- TRATION	
						(a)	(b)	(c)	(a)	(b)	(c)		(a)	(b)
						1-20	21-50	51-100	1-20	21-50	51-100		FIG. NO.	ITEM NO.
P F	5320-952-4159	RIVET: SKID MTG AD64S (07707)	.	EA	68	REF	REF	REF	REF	REF	REF			

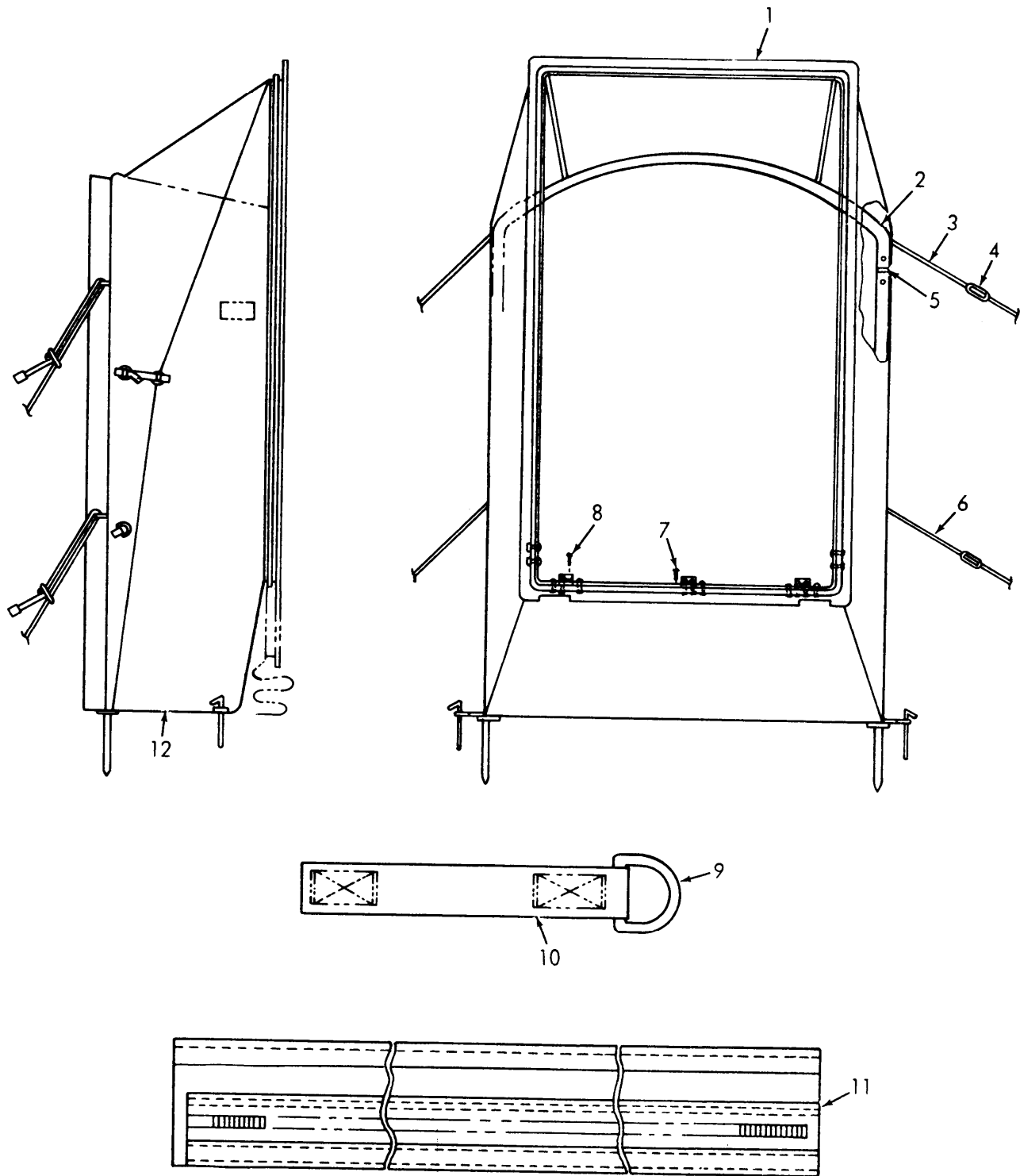

ME 5410-223-24P/1

Figure 1. Airlock Adapter

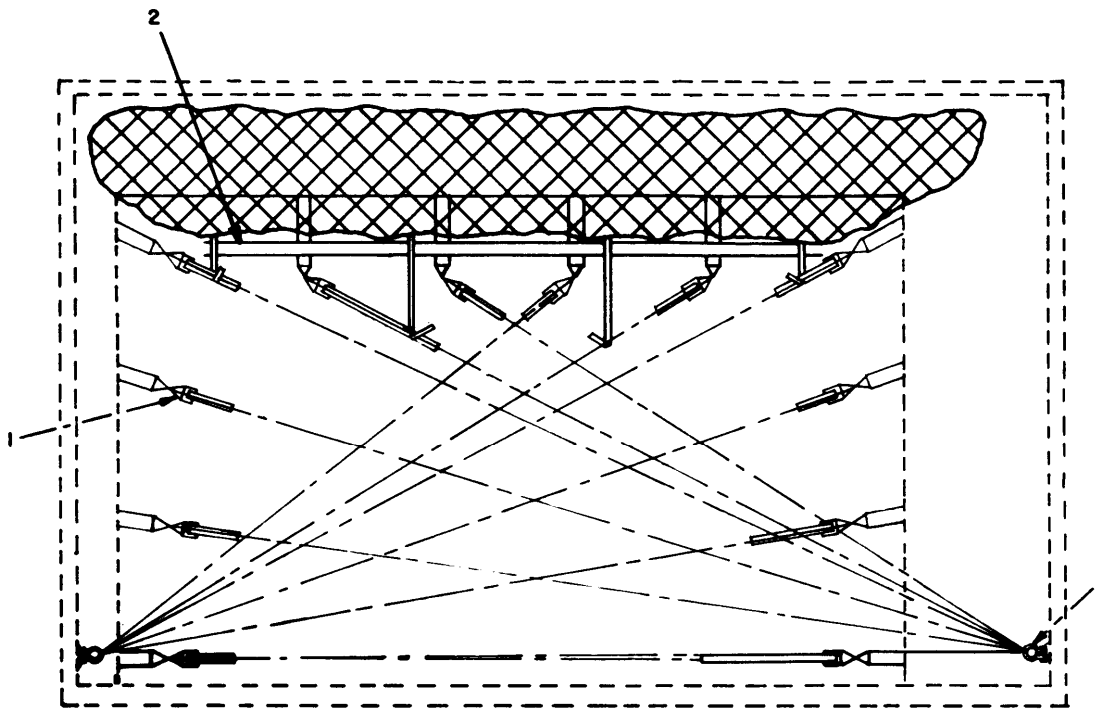

ME 5410-223-24P/2

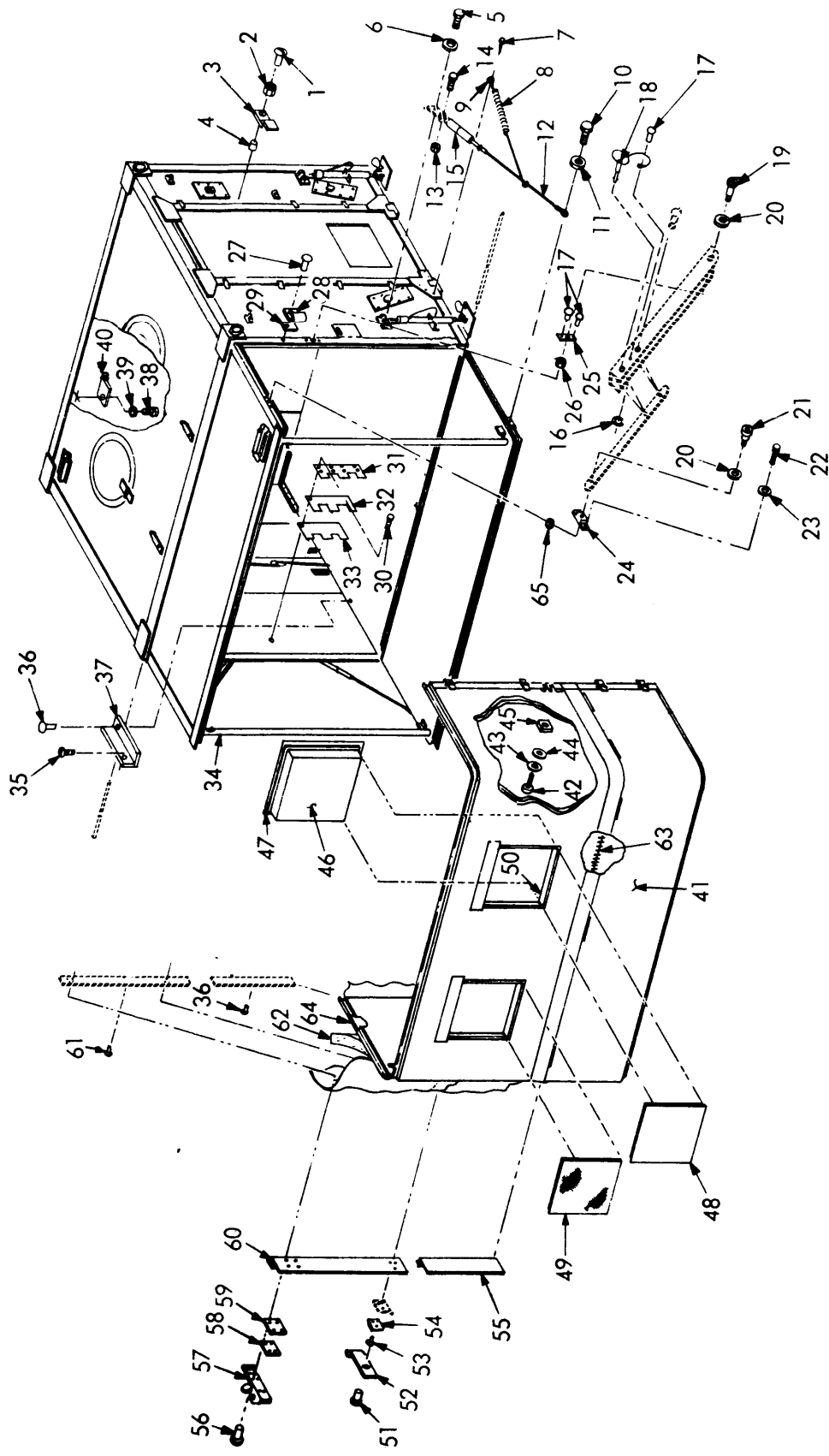

ME 5410-223-24P/3

Figure 3. Container

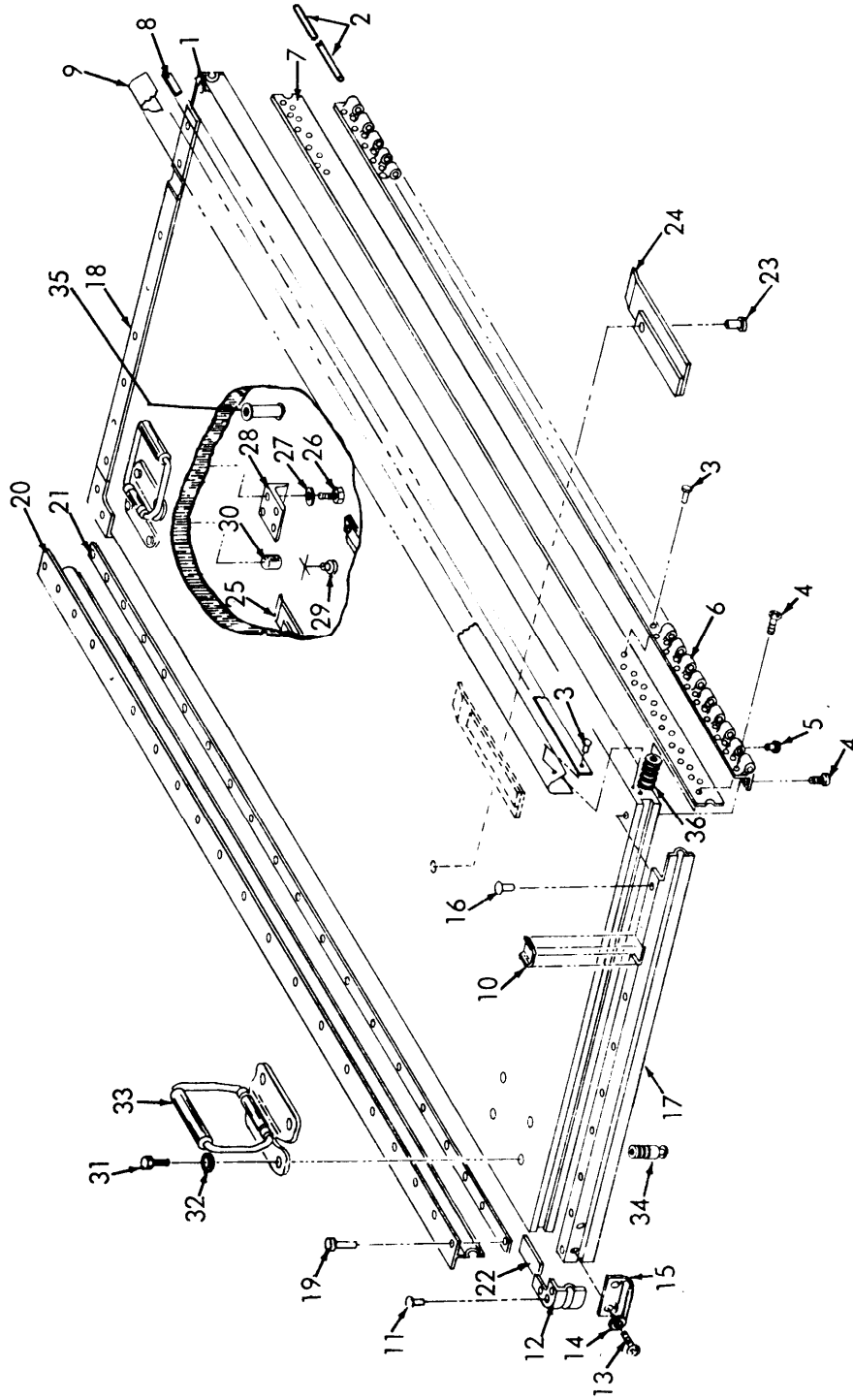

ME 5410-223-24P/4

Figure 4. Folding Roof

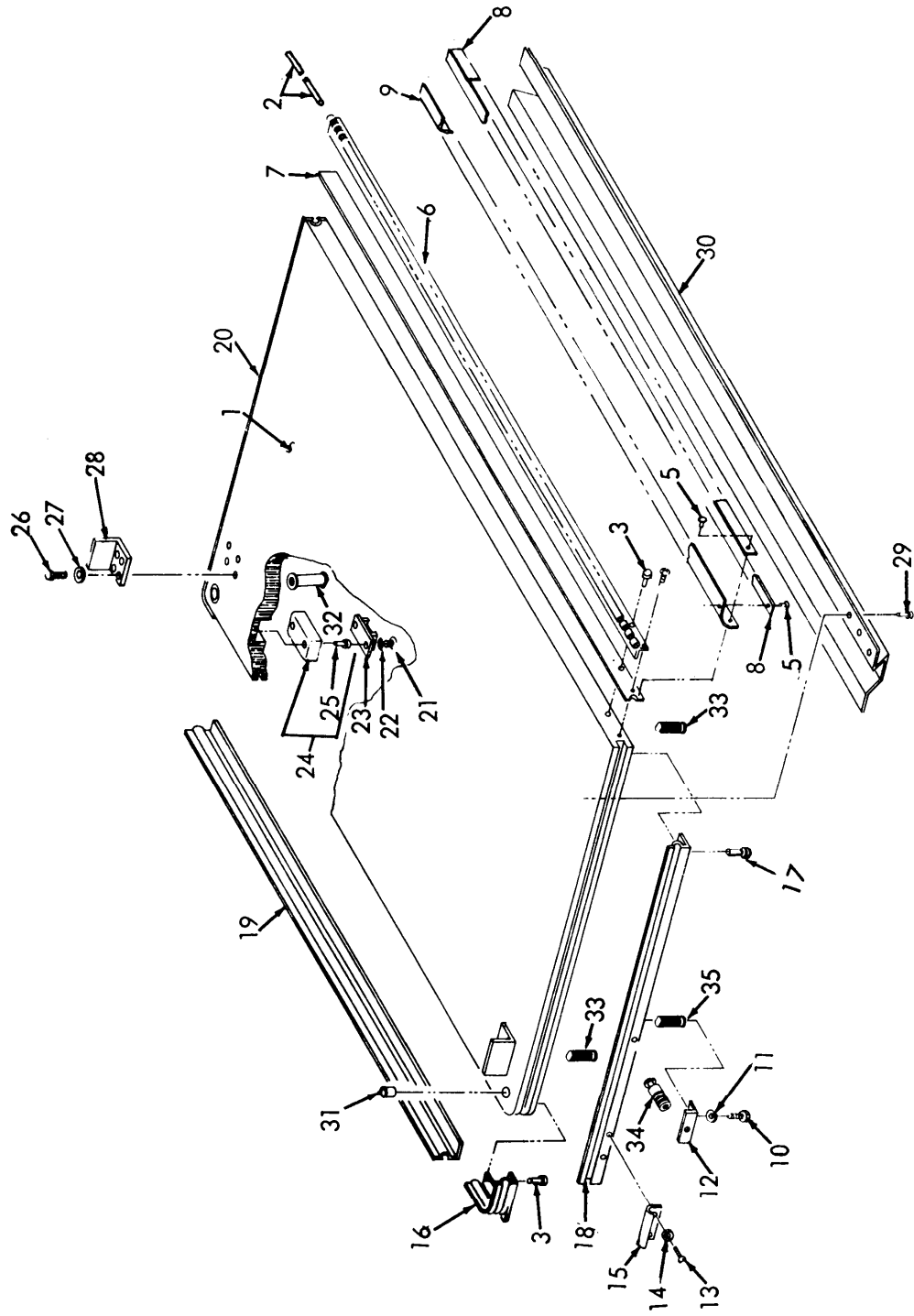

ME 5410-223-24P/5

Figure 5. Folding Floor

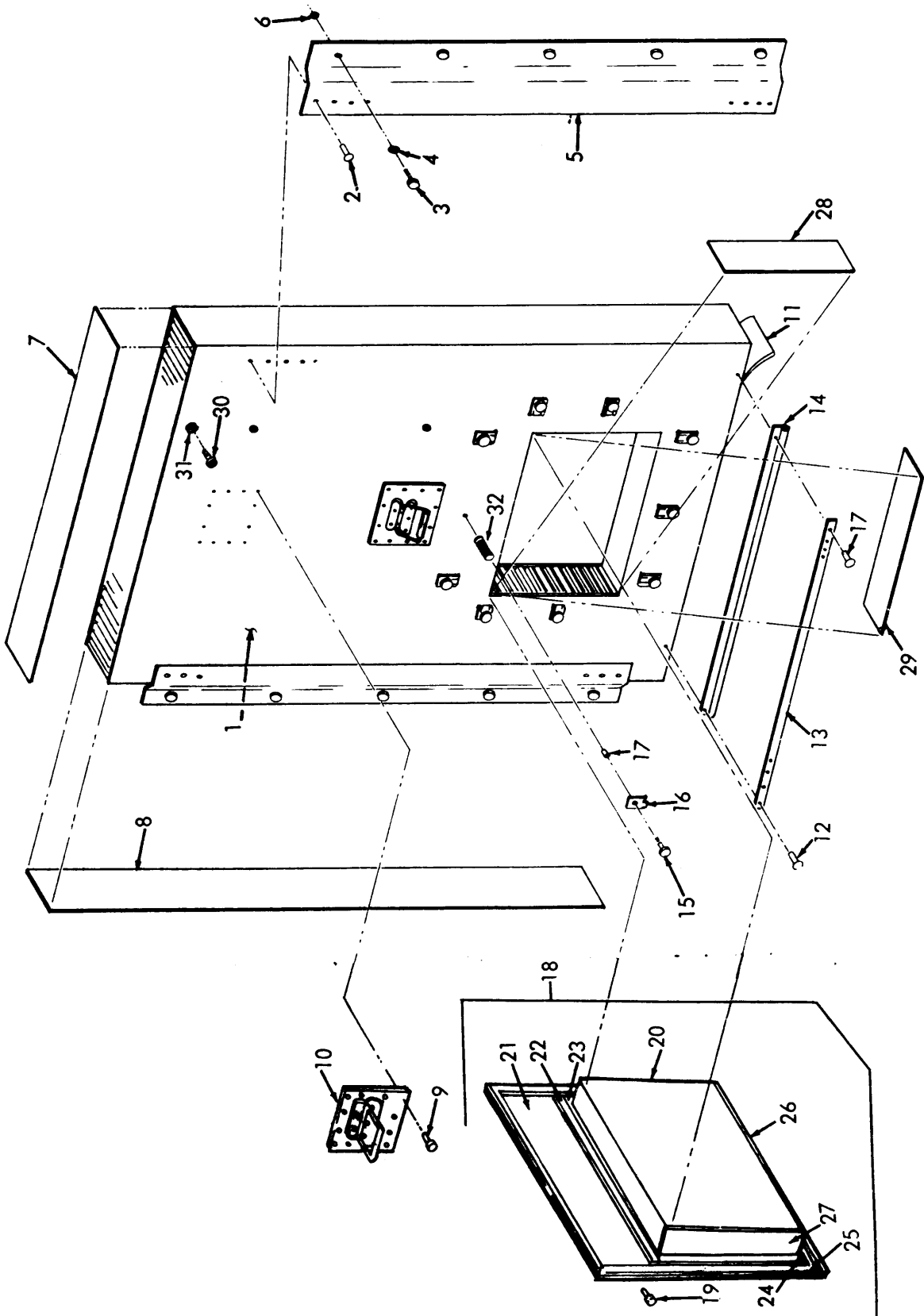

ME 5410-223-24P/6

Figure 6. Removable Door

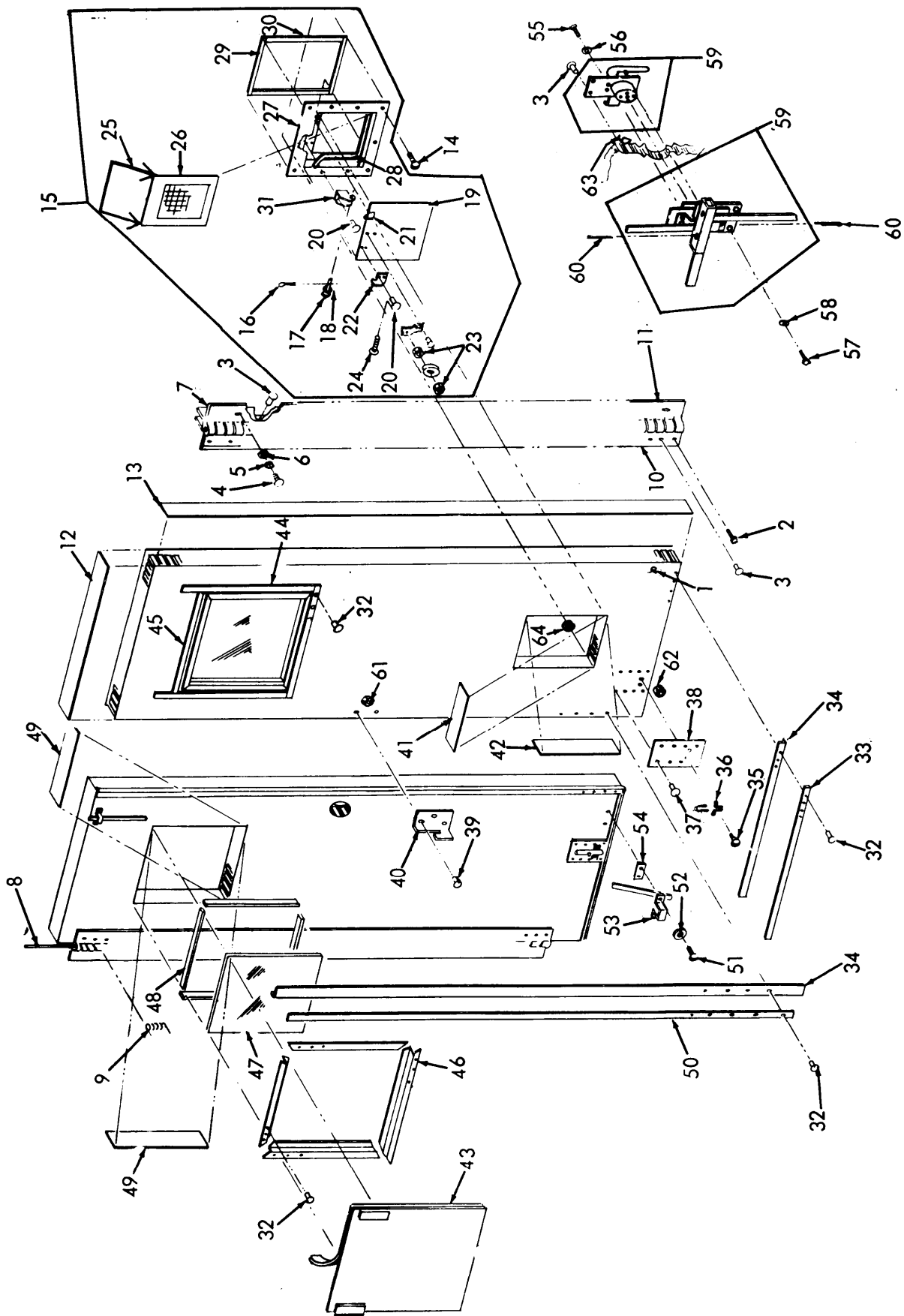
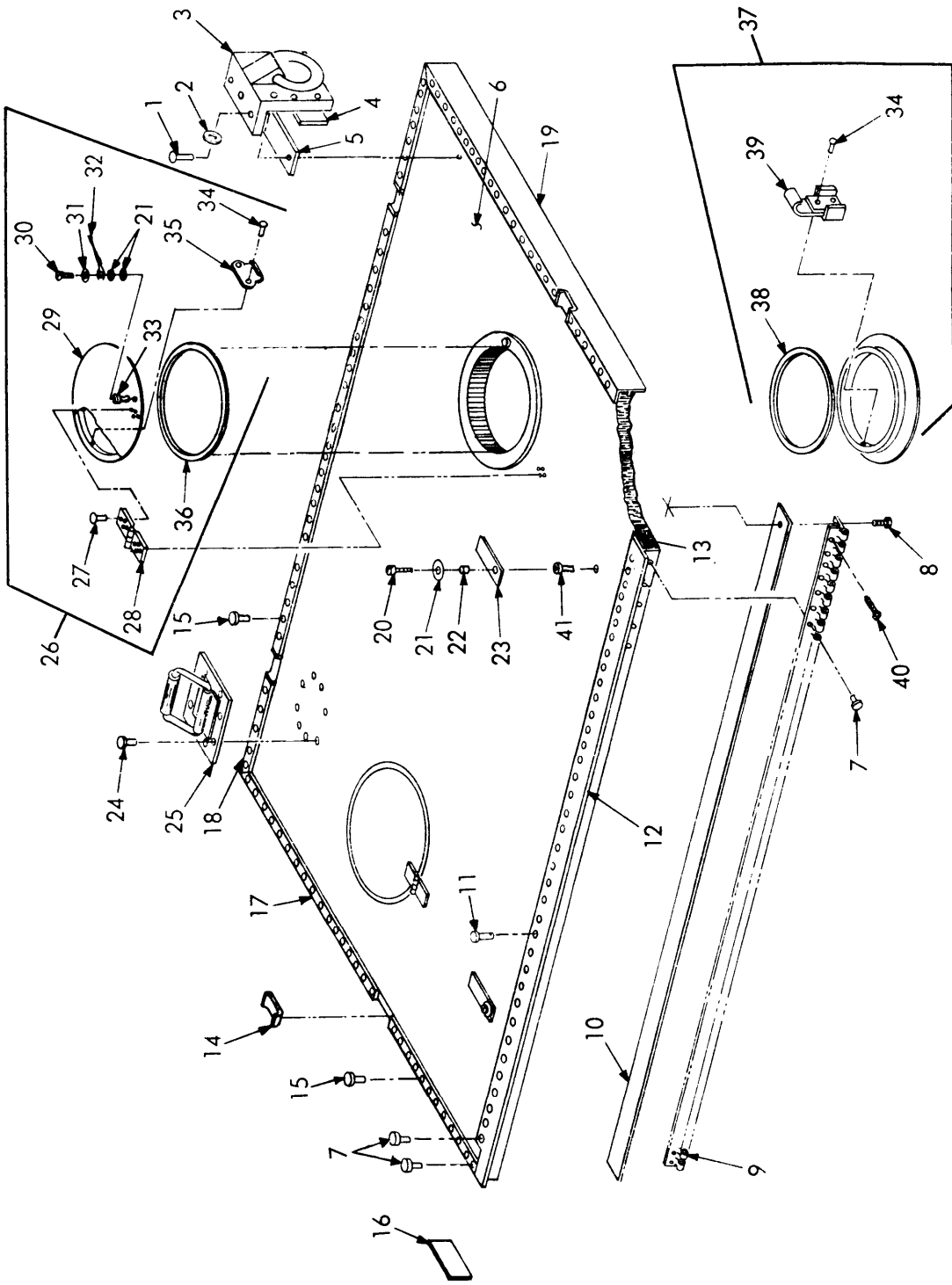
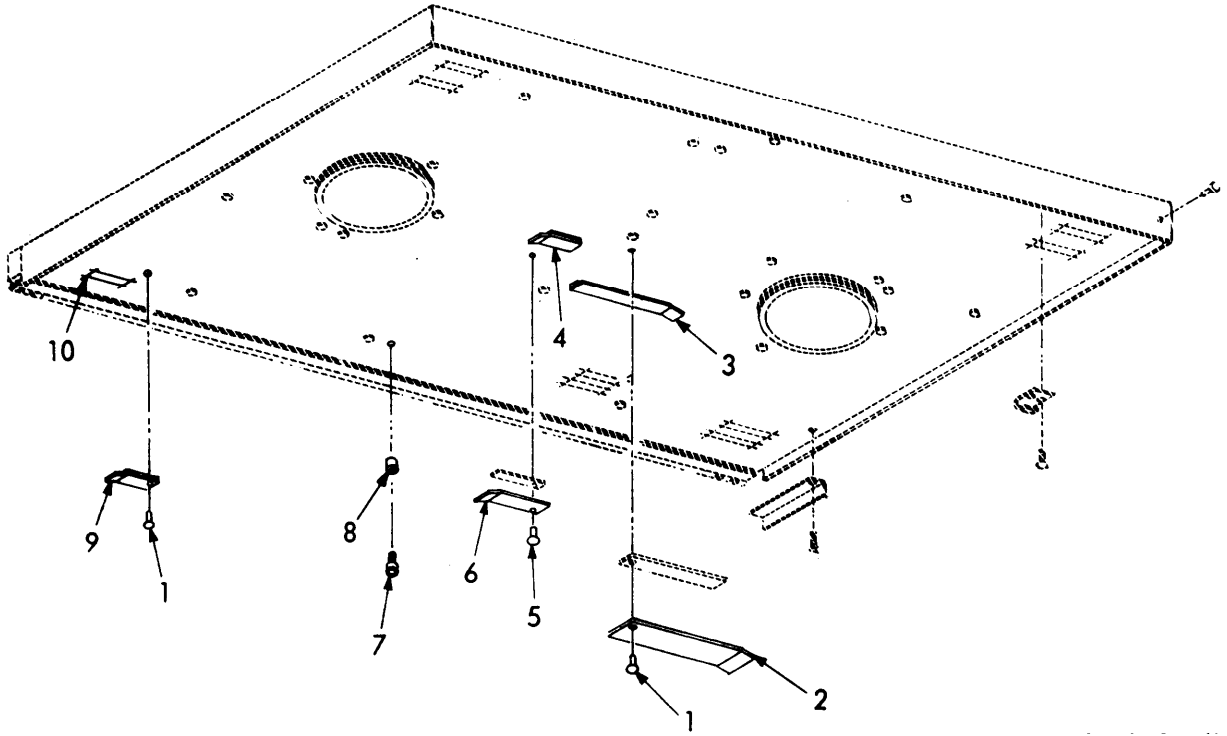

Figure 7. Door



ME 5410-223-24P/8

Figure 8. Roof Panel



ME 5410-223-24P/9

Figure 9. Roof Panel (Inside)

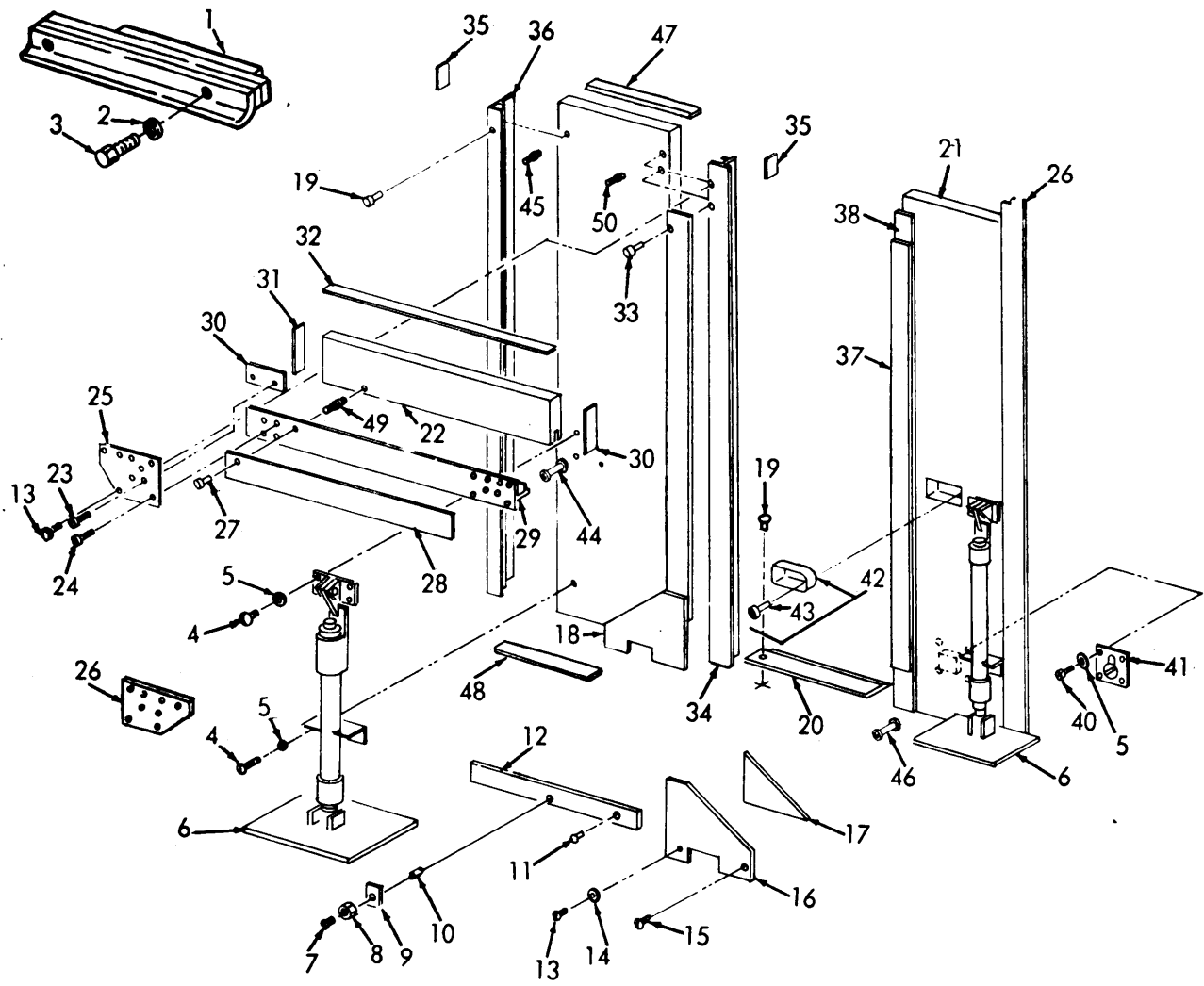

ME 5410-223-24P/10

Figure 10. End Panel

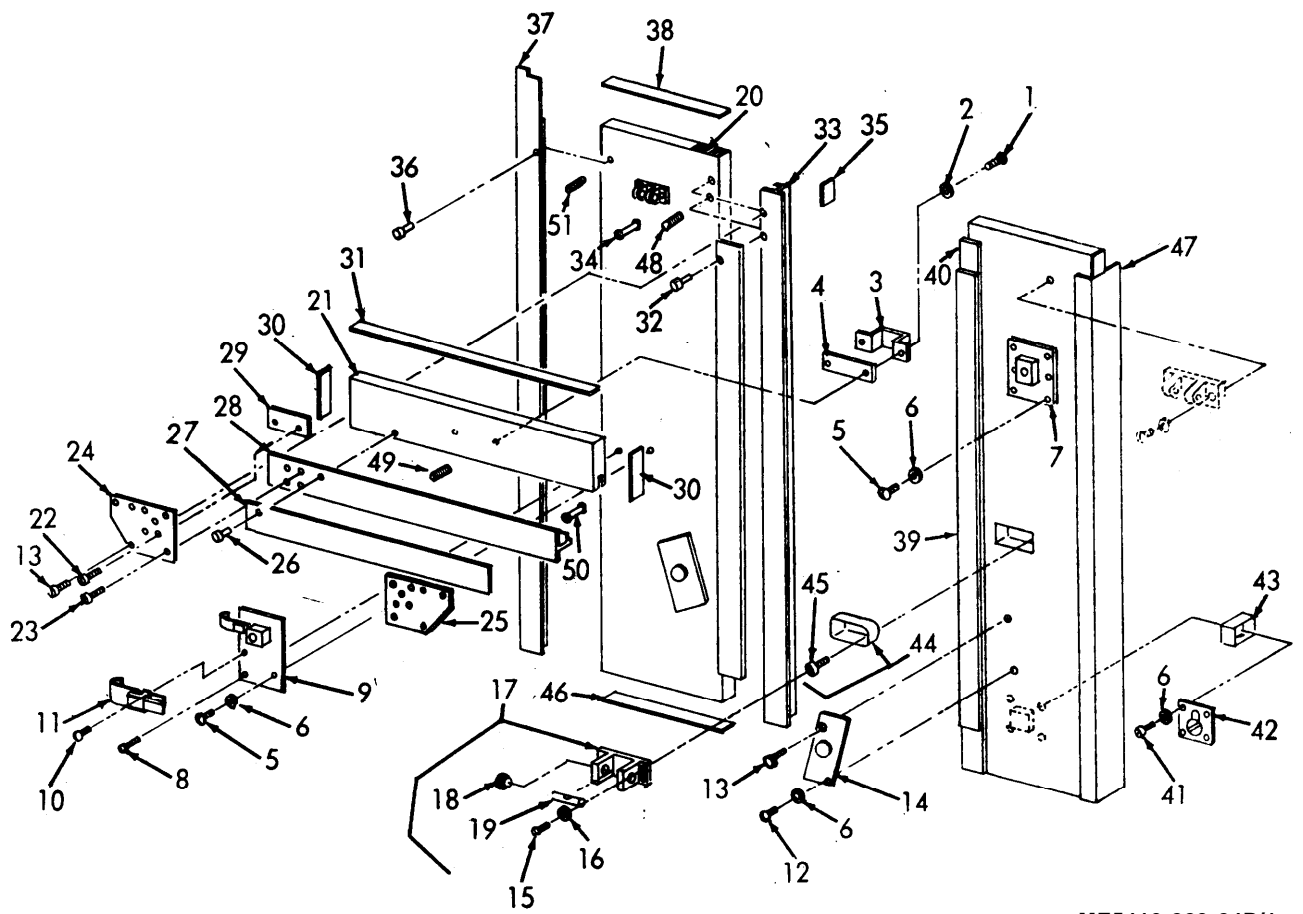

ME5410-223-24P/1

Figure 11. End Panel

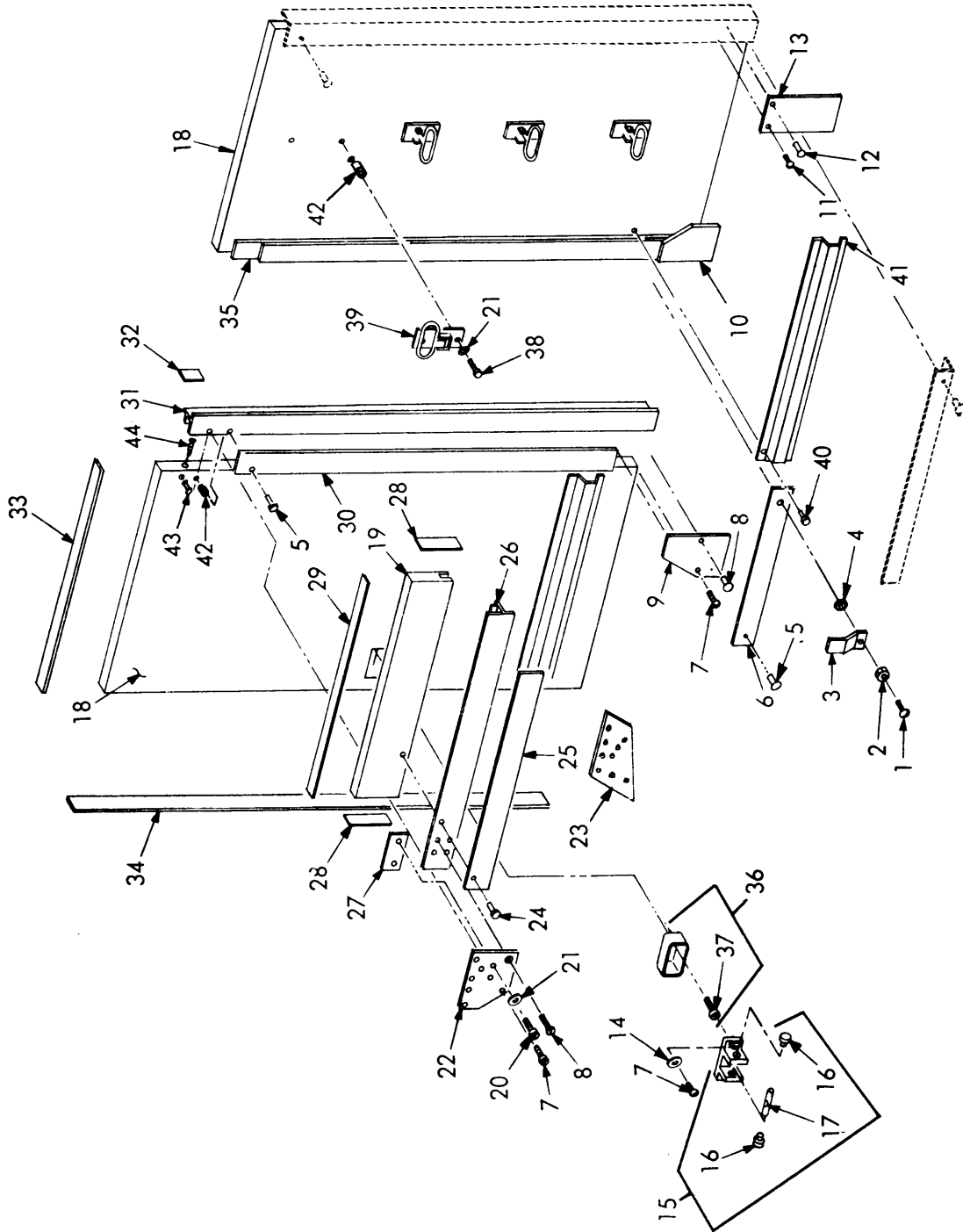

ME 5410-223-24P/12

Figure 12. Side Panel

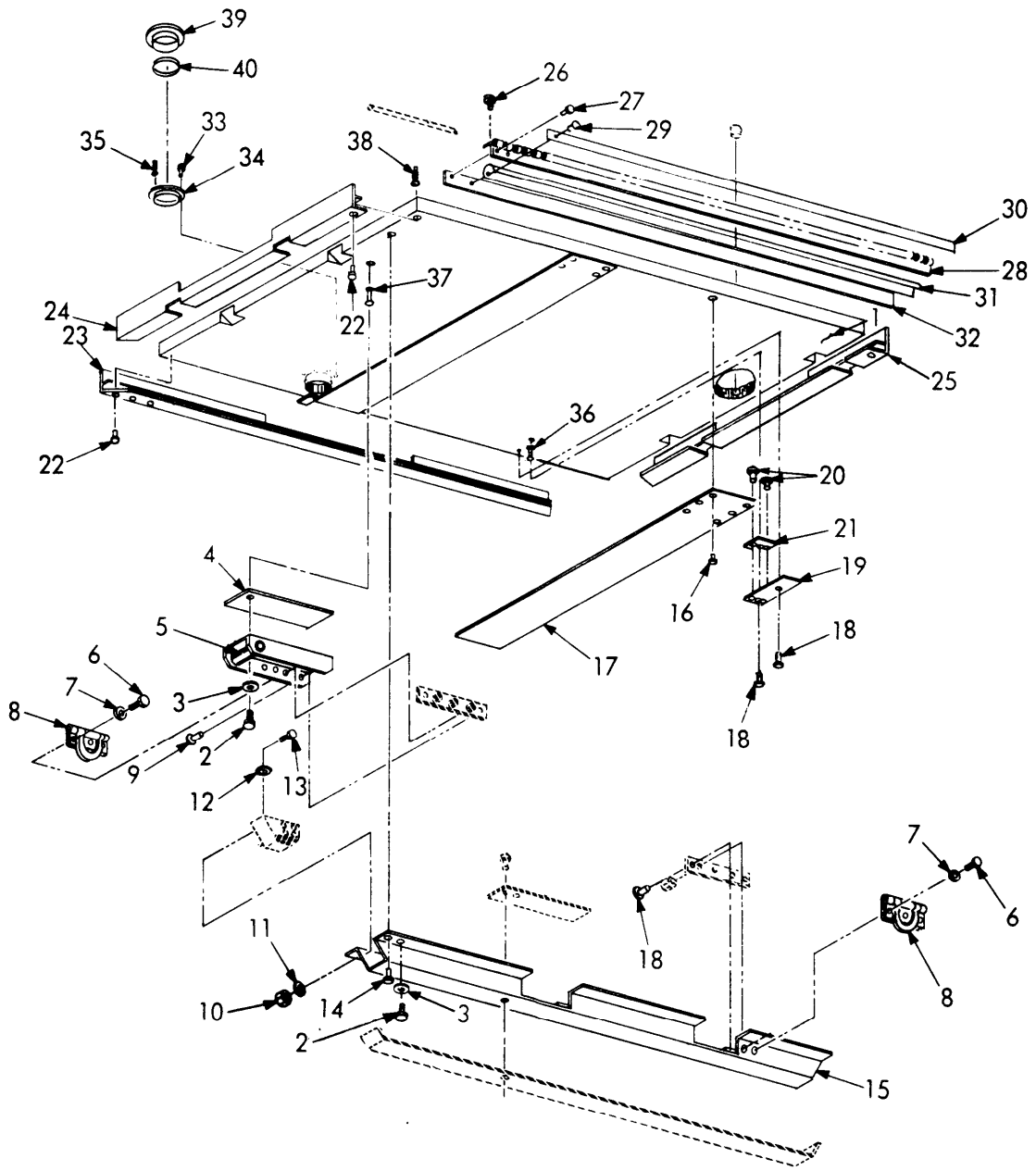

ME 5410-223-24P/13

Figure 13. Floor Panel

Section VII. INDEX-FEDERAL STOCK NUMBER AND REFERENCE NUMBER
CROSS-REFERENCE TO FIGURE AND ITEM NUMBER

<u>Stock Number</u>	<u>Figure No.</u>	<u>Item No.</u>	<u>Stock Number</u>	<u>Figure No.</u>	<u>Item No.</u>
1670-885-0855	10	41	5310-917-6086	5	25
	11	42		10	43
5210-134-3248	5	23		11	45
	11	17		12	37
	12	15	5310-957-6533	8	33
5305-043-2677	11	13	5315-812-3775	7	17
5305-043-2682	7	39	5315-839-2325	7	16
	11	10		7	60
5305-C67-9850	3	35	5320-117-6844	1	8
5305-068-0505	7	51	5320-117-6949	3	61
5305-068-0507	11	1		8	34
5305-068-0514	11	5		8	34
5305-225-3839	13	6	5320-117-6950	3	17
5305-253-2606	6	15	5320-117-6951	7	20
5305-267-8577	7	57	5320-117-6953	4	11
5305-269-3235	10	4		13	20
5305-337-3090	13	18	5320-143-6149	3	53
5305-719-5121	7	24	5320-420-2163	13	14
5305-781-5690	4	4	5320-420-2165	4	5
	5	4		5	3
	8	8		8	7
5305-891-1783	4	13		10	27
	5	13		11	26
5305-957-7811	7	35		12	24
5305-957-7814	13	33		13	27
5305-964-9221	13	26	5320-462-2320	12	40
5305-993-2461	7	4	5320-486-8251	4	3
5305-995-3444	8	20		5	5
5306-144-4004	3	14		13	29
5306-150-9105	4	31	5320-490-2238	5	29
5306-151-1426	5	10		7	37
5306-225-9081	12	11	5320-619-4093	1	7
5306-225-9089	13	2	5320-778-3352	7	64
5306-515-8064	10	3	5320-855-2185	10	24
5306-531-8979	4	26		11	23
	5	26		12	8
5306-838-7487	3	7		12	8
	10	15	5320-882-8385	3	56
5310-045-3296	8	31		4	19
5310-081-4219	13	3		8	11
5310-167-0667	3	23		10	11
	4	14		12	12
	5	14		13	9
5310-167-0672	4	27	5320-882-8386	8	24
	5	27		9	5
5310-167-0812	3	39	5320-882-8388	3	36
5310-167-0816	7	18		3	36
5310-167-0818	5	22		4	23
	8	21		6	19
	8	21		8	27
	11	16		9	1
	13	12	5320-932-1972	6	9
5310-167-0820	8	2		6	12
	10	14		7	32
	12	21	5320-952-4159	13	16
5310-167-0821	10	5	5320-956-7355	3	27
5310-167-0823	3	6		4	16
	3	11		5	17
5310-167-0834	13	11		6	2
5310-167-0839	3	20		7	3
5310-176-8121	3	2		8	15
	10	8		10	19
	12	2		10	19
5310-181-6033	10	10		11	36
5310-188-3744	7	56		13	22
5310-194-0637	7	52	5325-264-0823	1	11
	7	58	5325-276-4930	4	29
	11	2		6	30
	13	7	5325-281-4782	3	44
5310-194-8023	8	41	5325-281-8643	3	43
5310-529-6513	3	4	5325-371-8109	3	45
	6	17	5325-550-4360	3	28
	12	4		3	57
5310-595-5427	4	32	5325-619-0843	3	42
	5	11	5340-022-3161	7	9
	6	4	5340-022-3167	7	7
	7	5	5340-022-3169	7	21
	10	2	5340-022-3172	7	22
	10	4	5340-042-8664	2	1
	10	5	5340-042-8682	7	61
	11	6		7	61
5310-685-2651	7	23	5340-042-8683	3	65

Section VII. INDEX-FEDERAL STOCK NUMBER AND REFERENCE NUMBER
CROSS-REFERENCE TO FIGURE AND ITEM NUMBER

<u>Stock Number</u>	<u>Figure No.</u>	<u>Item No.</u>
5340-042-8683	13	37
5340-067-9884	3	15
5340-182-4603	13	35
5340-236-8352	4	6
	5	6
	8	9
	13	28
5340-262-4134	1	9
5340-780-7183	7	36
5340-811-6643	3	16
5340-978-7995	8	35
5340-992-8141	8	39
5360-251-4006	3	8
5410-018-7464	8	37
5410-018-7538	2	2
5410-022-2664	8	26
5410-022-2665	10	6
5410-221-8901	3	46
5410-221-8902	6	16
5410-221-8903	8	28
5410-221-8904	11	11
5410-299-1182	13	8
5410-522-2475	3	12
5410-522-2479	3	34
5410-522-2482	8	3
5995-804-6728	8	32
6625-568-7798	12	39
8340-205-2759	1	4
9330-234-6452	7	47

Section VII. INDEX-FEDERAL STOCK NUMBER AND REFERENCE NUMBER
CROSS-REFERENCE TO FIGURE AND ITEM NUMBER

Reference No.	Mfg Code	Fig No.	Item No.	Reference No.	Mfg Code	Fig No.	Item No.
AD64S	07707	13	16	MILR24243-6A604H	81349	7	3
AD86BS	07707	3	51		81349	8	15
AN3-4A	88044	7	55		81349	10	19
AN345C416	88044	12	2		81349	10	19
AN354C416	88044	3	2		81349	10	27
	88044	10	8		81349	11	26
AN4-4A	88044	4	31		81349	11	36
AN4-5A	88044	11	12		81349	13	22
AN4-6A	88044	3	22	MILR24243-6A606H	81349	3	56
	88044	5	10		81349	4	19
AN4-7A	88044	10	3		81349	8	11
AN5-7A	88044	12	38		81349	10	11
AN507-1032-8	88044	13	18		81349	12	12
AN520C10R10	88044	3	38		81349	13	9
AN526DD1032-8	88044	8	30	MILR24243-7A403H	81349	3	53
AN6-12A	88044	3	14	MILR24243-7A602H	81349	4	3
AN6-7A	88044	4	26		81349	5	5
	88044	5	26	MILR24243-7A604F	81349	13	14
AN935-10	88044	8	31	MILR24243-7A604H	81349	4	5
AN935-416L	88044	3	23		81349	5	3
	88044	4	14		81349	8	7
	88044	5	14		81349	12	24
AN935-616L	88044	4	27		81349	13	27
	88044	5	27	MILR24243-7A606H	81349	10	33
AN960-10	88044	5	22		81349	11	32
	88044	8	21		81349	12	5
	88044	8	21		81349	12	5
	88044	11	16	MILR242437A602H	81349	13	29
	88044	13	12	MILR3390STYLE1	81349	1	9
AN960-10L	88044	13	11	MILS1734TYII	81349	1	4
AN960-416	8044	10	4	MILW4088TYXVII	81349	1	10
	88044	4	32	MS20253P5-1390	96906	4	2
	88044	5	11		96906	5	2
	88044	6	4	MS20253P5-6600	96906	7	8
	88044	7	5	MS20365-1032	96906	13	10
	88044	10	2	MS20365-624	96906	3	13
	88044	10	5	MS20392-1C25	96906	7	17
	88044	11	6	MS20426AD4-4	96906	3	61
AN960-516	88044	8	2		96906	8	34
	88044	10	14		96906	8	34
	88044	12	21	MS20426AD4-5	96906	3	17
AN960-6	88044	7	18	MS20426AD4-6	96906	7	20
AN960-616	88044	10	5	MS20426AD4-8	96906	4	11
AN960-816	88044	3	6		96906	13	20
	88044	3	11	MS20426AD4-9	96906	1	7
AN960-816L	88044	3	20	MS20426A6-9	96906	10	24
AN960C10L	88044	3	39		96906	11	23
A10B116	03481	8	33		96906	12	8
A10B130	03481	8	41		96906	12	8
A10B190	25472	7	62	MS20470AD5-12	96906	1	8
BN360-1032-1	73197	7	64	MS21251-8L	96906	3	15
BN514-332-8	73197	13	35	MS24584-57	96906	5	21
BN528-428-1-24	73197	7	61		96906	11	15
	73197	7	61	MS24665-132	96906	7	16
BN528-428-3-24	73197	3	65		96906	7	60
BN528-524-3-24	73197	13	37	MS24693S-272	96906	7	35
BS78403	61864	3	43	MS24693S122	96906	3	35
BS78505	61864	3	44	MS24693S294	96906	13	26
BS78507	61864	3	45	MS24693S48	96906	13	33
CL32SS	99862	3	21	MS24693S94	96906	4	4
CL4SS	99862	3	19		96906	5	4
HS250-39S	98003	4	15		96906	8	8
	98003	5	15	MS24694S94	96906	11	13
HS250-49S	98003	3	52	MS24694S98	96906	7	39
MILR24243-6A402H	81349	6	9		96906	11	10
	81349	6	12	MS25082-4	96906	7	23
	81349	7	32	MS25083-2B88	96906	8	32
MILR24243-6A403H	81349	3	36	MS27039-4-10	96906	4	13
	81349	3	36		96906	5	13
	81349	4	23	MS27183-12	96906	13	3
	81349	6	19	MS27940-13N	96906	9	7
	81349	8	27	MS27980-13N	96906	4	29
	81349	9	1		96906	6	30
MILR24243-6A404H	81349	8	24	MS35207-266	96906	8	20
	81349	9	5	MS35224-63	96906	7	14
MILR24243-6A502H	81349	12	40	MS35224-81	96906	7	2
MILR24243-6A503H	81349	5	29	MS35234-84	96906	3	1
	81349	7	37		96906	10	7
MILR24243-6A604H	81349	3	27		96906	12	1
	81349	4	16	MS35308-307	96906	10	40
	81349	5	17		96906	11	41
	81349	6	2	MS51937-3	96906	1	5

Section VII. INDEX-FEDERAL STOCK NUMBER AND REFERENCE NUMBER
CROSS-REFERENCE TO FIGURE AND ITEM NUMBER

Reference No.	Mfg Code	Fig No.	Item No.	Reference No.	Mfg Code	Fig No.	Item No.
MS51960-86	96906	7	24	ZSD14-117-1	26533	7	9
MS90725-36	96906	12	11	ZSD14-194	26533	3	8
MS90725-8	96906	13	6	ZSD16-181-1	26533	5	24
MS90726-10	96906	7	57		26533	10	42
MS90726-34	96906	13	2		26533	11	44
MS90726-5	96906	7	51		26533	12	36
MS90726-7	96906	11	1	ZSD18-180-401	26533	7	59
MS90727-59	96906	10	4	ZSP2-210-1	26533	8	39
MS90727-7	96906	11	5	ZSP2-210-3	26533	8	35
MS9320-09	96906	7	56	ZSP3-003-2	26533	4	33
MS9320-10	96906	7	52	12705L8C8C	56878	3	5
	96906	7	58		56878	3	10
	96906	11	2	21-8X35	32868	11	19
	96906	13	7		32868	12	17
NAS1102-08-6	80205	11	8	48-41-4-24	94222	6	6
NAS1102-5-12	80205	10	13		94222	7	6
	80205	10	13	5-4-1630-1	81337	1	1
	80205	11	13	5-4-1630-10	81337	1	6
	80205	12	7	5-4-1630-11	81337	1	3
	80205	12	7	5-4-1630-2	81337	1	1
NAS1103-5-6	80205	12	20	5-4-1630-3	81337	1	2
NAS1103-7W	80205	13	13	5-4-1630-4	81337	1	12
NAS1105-3	80205	8	1	50603S4R04L5	84256	3	18
NAS1105-4	80205	3	7	5133-50	79136	3	16
	80205	10	15	575709	19220	12	39
NAS1105-5-6	80205	10	23	697281-1	02106	7	15
	80205	11	22	697282-1	02106	7	27
NAS1155-11	80205	3	30	697282-23	02106	7	31
NAS1329A08B75	80205	6	31	697282-25	02106	7	28
	80205	9	8	697282-27	02106	7	30
NQ2	82240	3	28	697282-29	02106	7	29
	82240	3	57	697283-11	02106	7	19
SP2158-3	96603	10	41	697283-13	02106	7	21
	96603	11	42	697283-15	02106	7	22
SP2804-2	96603	13	8	697285-1	02106	7	25
SS10K880	03481	10	43	697285-11	02106	7	26
	03481	11	45	697899-1	02106	2	1
	03481	12	37	697899-2	02106	2	2
	26533	5	25	698720-2	7C167	1	11
S8157C127-100	79144	10	10	820338-25	02106	7	50
S8157C127-156	79144	3	4	889199-1	02106	8	37
	79144	6	17	889199-11	02106	8	38
	79144	12	4	889200-1	02106	8	26
VF106TY4STYLE8SIZE	81348	3	63	889200-11	02106	8	26
VHC250-35S	98003	11	11	889211-1	02106	7	11
V1582	10424	8	3	889212-3	02106	7	10
X878332	61864	3	42	889220-1	02106	10	6
ZR14-6	26533	4	30	889238-1	02106	8	29
	26533	5	31	889247-1	02106	7	7
ZR31-25	26533	11	43	889253-1	02106	7	46
ZSD01-113-3	26533	5	30	889280-1	02106	7	43
ZSD01-113-4	26533	12	41	889283-1	02106	8	28
ZSD03-102-16	26533	10	46	889284-1	02106	8	23
ZSD03-102-3	26533	7	63	889507-1	02106	6	16
	26533	13	36	889508-1	02106	6	15
ZSD03-102-4	26533	11	50	889751-1	02106	3	40
ZSD03-102-5	26533	10	50	890331-11	02106	10	17
	26533	11	34	890331-13	02106	10	12
	26533	12	43	890331-15	02106	12	6
ZSD03-102-9	26533	4	35	890331-17	02106	4	8
	26533	5	32		02106	5	8
ZSD03-169-1	26533	4	36		02106	13	30
	26533	5	33	890331-19	02106	4	9
	26533	6	32		02106	5	9
	26533	8	40		02106	13	31
	26533	10	49	890331-21	02106	3	37
	26533	12	44	890331-29	02106	3	29
	26533	13	38	890331-33	02106	8	5
ZSD03-189-1	26533	3	26	890331-35	02106	8	4
	26533	5	34	890332-1	02106	8	6
ZSD03-189-2	26533	11	48	890332-13	02106	8	13
	26533	12	42	890332-15	02106	8	17
ZSD03-189-3	26533	4	34	890332-17	02106	8	19
	26533	11	49	890332-19	02106	8	18
ZSD03-191	26533	5	35	890332-21	02106	8	16
	26533	10	45	890332-23	02106	8	10
	26533	11	51	890332-25	02106	8	12
ZSD03-192	26533	10	44	890332-27	02106	4	10
ZSD06-195	26533	3	9		02106	8	14
ZSD06-197-3	26533	6	3	890333-1	02106	12	18
ZSD06-1973	02106	7	4	890333-13	02106	12	35
ZSD07-132	26533	8	22	890333-14	02106	12	31

Section VII. INDEX-FEDERAL STOCK NUMBER AND REFERENCE NUMBER
CROSS-REFERENCE TO FIGURE AND ITEM NUMBER

Reference No.	Mfg Code	Fig No.	Item No.	Reference No.	Mfg Code	Fig No.	Item No.
890333-15	02106	12	33	890340-63	02106	3	62
890333-17	02106	12	34	890340-67	02106	3	62
890333-19	02106	12	32	890340-7	02106	3	46
890333-21	02106	12	30	890340-77	02106	3	60
890334-1	02106	10	21	890340-78	02106	3	60
890334-17	02106	10	36	890340-80	02106	3	55
890334-18	02106	11	37	890340-81	02106	3	64
890334-19	02106	10	34	890340-83	02106	3	50
	02106	11	33	890340-89	02106	3	47
890334-20	02106	10	38	890340-9	02106	3	48
	02106	11	40	890341-1	02106	13	1
890334-21	02106	10	39	890341-13	02106	13	34
890334-22	02106	11	47	890341-21	02106	13	4
890334-23	02106	10	35	890341-23	02106	13	32
	02106	11	35	890341-25	02106	13	23
890334-27	02106	10	47	890341-28	02106	13	25
	02106	11	38	890341-3	02106	13	
890334-29	02106	10	48	890341-37	02106	13	24
	02106	11	46	890342-1	02106	13	
890334-3	02106	11	20	890342-11	02106	13	15
890334-31	02106	10	37	890345-1	02106	10	22
	02106	11	39		02106	11	21
890335-1	02106	6	1		02106	12	19
890335-11	02106	6	20	890345-13	02106	10	29
890335-13	02106	6	13		02106	11	28
890335-15	02106	6	11		26533	12	26
890335-19	02106	6	8	890345-15	02106	10	32
890335-21	02106	6	7		02106	11	31
890335-23	02106	6	29		02106	12	29
890335-25	02106	6	28	890345-17	02106	10	31
890335-27	02106	6	14		02106	11	30
890335-3	02106	6	1		02106	12	28
	02106	6	10	890345-19	02106	10	28
890335-5	02106	8	25		02106	11	27
	02106	5	1		02106	12	25
890336-1	02106	5	12	890345-21	02106	10	26
890336-11	02106	5	18		02106	11	25
890336-15	02106	5	20		02106	12	23
890336-16	02106	5	19	890345-22	02106	10	25
890336-17	02106	5	16		02106	11	24
890336-19	02106	5	7		02106	12	22
890336-21	02106	4	1	890345-23	02106	10	30
890337-1	02106	4	21		02106	11	29
890337-11	02106	4	18		02106	12	27
890337-15	02106	4	17	890346-1	02106	11	9
890337-16	02106	4	20	890347-11	02106	13	5
890337-17	02106	4	12	890348-1	02106	11	14
890337-19	02106	4	7	890349-1	02106	10	18
890337-21	02106	4	22	890349-2	02106	10	16
890337-23	02106	7	1	890350-1	02106	12	10
890338-1	02106	11	3	890350-2	02106	12	9
890338-15	02106	7	53	890351-1	02106	12	13
	02106	11	3	890353-1	02106	3	33
890338-17	02106	11	4	890354-1	02106	4	28
	02106	7	40		02106	5	28
890338-19	02106	7	48	890356-1	02106	8	9
890338-21	02106	7	47		02106	13	28
890338-23	02106	7	33	890356-3	02106	4	6
890338-27	02106	7	34		02106	5	6
890338-29	02106	7	1	890357-1	02106	5	23
890338-3	02106	7	38		02106	11	17
890338-31	02106	7	49		02106	12	15
890338-33	02106	7	41	890357-13	02106	11	18
890338-35	02106	7	42		02106	12	16
890338-37	02106	7	13	890358-1	02106	3	31
890338-39	02106	7	12	890359-15	02106	3	24
890338-41	02106	7	44	890359-17	02106	3	25
890338-43	02106	7	45	890360-1	02106	3	12
890338-45	02106	6	18	890361-1	02106	6	5
890339-1	02106	6	21	890362-1	02106	10	20
890339-13	02106	6	22	890363-1	02106	3	34
890339-15	02106	6	23	890364-1	02106	3	32
890339-17	02106	6	24	890365-1	02106	13	39
890339-19	02106	6	25	890365-17	02106	13	40
890339-21	02106	6	27	890366-1	02106	13	17
890339-23	02106	6	26	890367-1	02106	11	7
890339-25	02106	3	41	891780-1	02106	10	9
890340-1	02106	3	49	891781-1	02106	3	3
890340-11	02106	3	59		02106	12	3
890340-115	02106	3	58	891782	02106	9	4
890340-121	02106	3	62	891782-1	02106	9	3
890340-17	02106	3	54	891782-2	02106	9	2
890340-59	02106	3					

Section VII. INDEX-FEDERAL STOCK NUMBER AND REFERENCE NUMBER
CROSS-REFERENCE TO FIGURE AND ITEM NUMBER

<u>Reference No.</u>	<u>Mfg Code</u>	<u>Fig No.</u>	<u>Item No.</u>
891782-4	02106	9	6
891782-5	02106	4	25
	02106	5	9
891782-6	02106	4	24
	02106	9	10
891783-1	02106	10	1
891785-11	02106	13	19
891785-13	02106	13	21

ITEMS NOT ILLUSTRATED

<u>Stock Number</u>	<u>Group No.</u>	<u>Reference No.</u>	<u>Mfg Code</u>	<u>Group No.</u>
5320-952-4159	02	AD64S	07707	02
5410-522-2480	02	MS24585-1294	96906	02
		MS51968-1	96906	02
		NAS1329A08B75	80205	02
		ZR31-25	26533	02
		889735-1	02106	01
		890334-25	02106	02
		890340-53	02106	02
		890340-61	02106	02
		890340-91	02106	02
		890340-123	02106	02
		890341-3	02106	02
		890342-1	02106	02
		890343-13	02106	02
		890343-15	02106	02
		890347-1	02106	02
		890347-2	02106	02
		890359-1	02106	02
		890359-2	02106	02
		890359-3	02106	02
		890359-4	02106	02
		890363-13	02106	02
		890363-15	02106	02
		890363-17	02106	02
		890363-19	02106	02

By Order of the Secretary of the Army:

Official:

KENNETH G. WICKHAM,
Major General, *United States Army*,
The Adjutant General.

W. C. WESTMORELAND,
General, United States Army,
Chief of Staff

Distribution:

To be distributed in accordance with DA Form 12-25, Sec I (qty rqr Block #278), Organizational maintenance requirements for Tents.

TM 10-5410-223-24P CONTAINER, SERVICE, WARD, RIGID CONSTRUCTION—1970